

▶ 6 FOOT VALANCE

ASSEMBLY INSTRUCTIONS

VALANCE FRAME

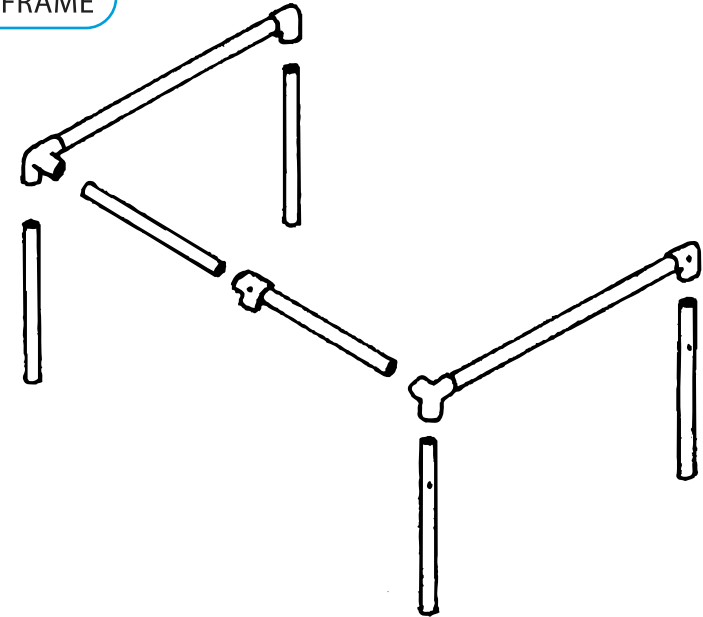
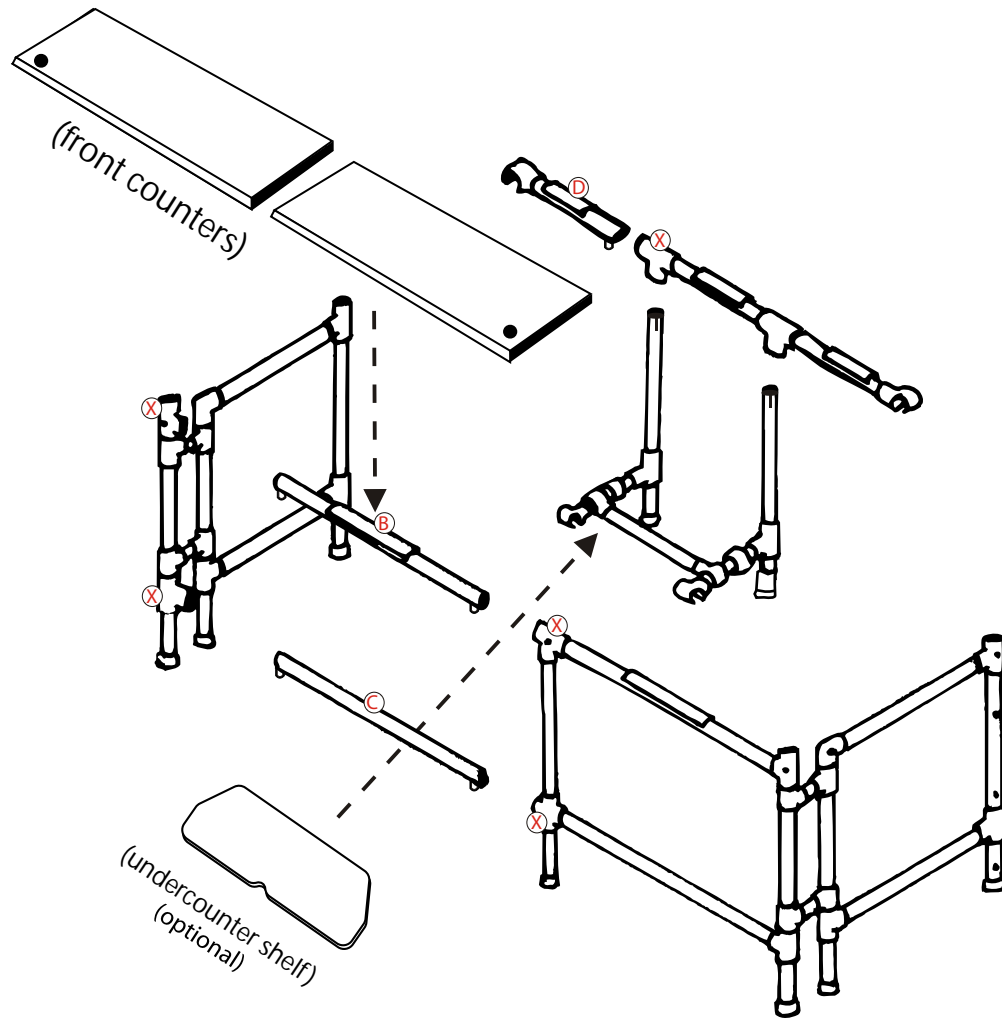

SETUP ▶

Booth Setup:

• Insert pipes with buttons (B, C, D) into fittings with button holes (X). As with valance assembly (above) be sure the button snaps into button hole securely.

• Position bottom frame into a rectangle with snaps facing out.

• Assemble valance frame, snap on valance vinyl.

• Lift the valance frame, insert into frame sockets.

* Snap skirt on, starting at one end.

+ Clip counter legs to frame. Attach counter support cross braces.

• Align counters over the frame and press down firmly to secure.

- Place undercounter shelf on bottom counter leg brace.

6 FOOT BOOTH CARRYING CASES & PRODUCT CARE INSTRUCTIONS

Thank you for purchasing The Great Gazebo, Inc. products. We have used the highest quality materials and manufacturing standards. To ensure that you obtain the best possible results, please read the instructions thoroughly and save for future reference.

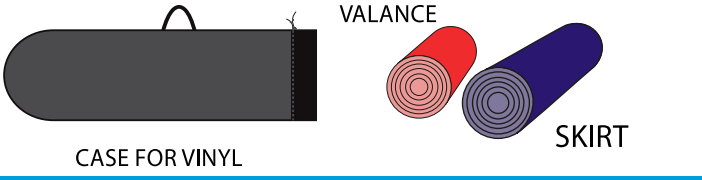

CASE FOR VINYL

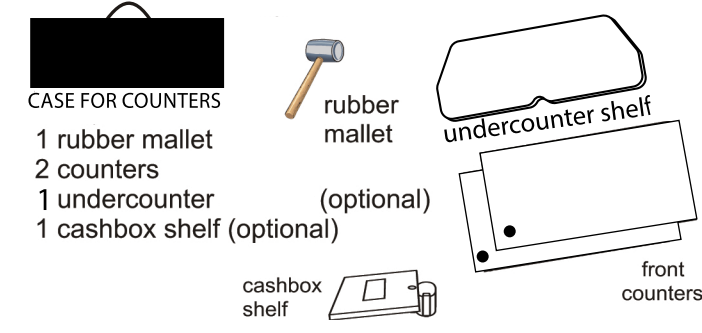

CASE FOR COUNTERS

- 1 rubber mallet
- 2 counters
- 1 undercounter
- 1 cashbox shelf (optional)

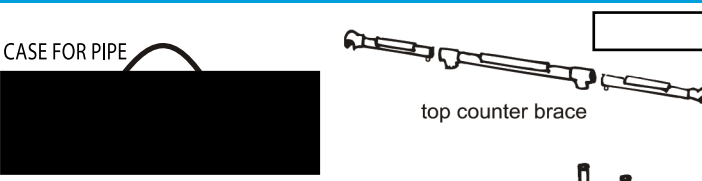

CASE FOR PIPE

CONTENTS:

- 1 valance frame
- 3 bottom counter braces
- 2 counter legs
- 1 top counter brace (3 parts)
- 2 frame cross pieces w/pins

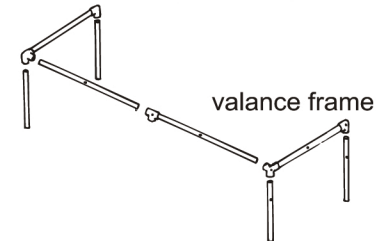

valance frame

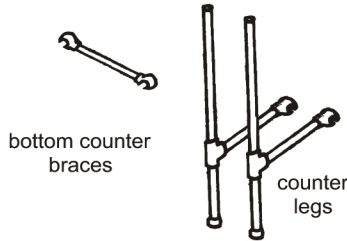

bottom counter braces

counter legs

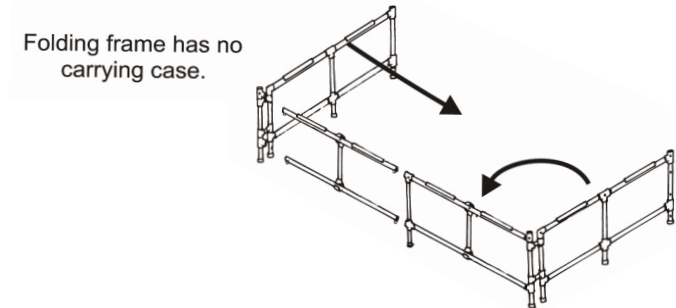

Folding frame has no carrying case.

For Storage:
Un-pin frame cross pieces with pins, fold the right side of the booth, and secure to the left side with string or bungee cord around top and bottom rails.

VINYL CARE

1. **WARNING!** Do not apply adhesive tape of any kind to the surface of printed vinyl. Doing so may damage the printing and WILL void the warranty.
2. **When storing vinyl**, make sure it's completely dry. This will prevent mold and mildew.
3. **Carefully fold top and roll skirt vinyl** (do not wad up) to avoid creases and wrinkles.
4. **Avoid placing heavy items** on top of folded or rolled vinyl. Proper care, folding the canopy and rolling the skirt will help the vinyl look good for years.
5. **Clean the outside of the vinyl** with soap & water. Vinyl preservatives extend the life of the vinyl. Do not scrub printed custom graphics.
6. Try not to let the **cloth backing** on the vinyl get dirty or stained. If it gets dirty, clean with warm soap and water and let it dry thoroughly before storing.
7. Do not fold the frame while the skirt is still snapped on. If the vinyl is cold it will be tight when snapping to the frame.
8. When unsnapping hold near the snap and pull straight. Do not yank or pull from a distance.

CARE OF PVC PIPES, COUNTER SUPPORTS & FRAME

1. **Clean with soap and water.** For stronger stains use a mild abrasive household cleaner such as Clorox Soft Scrub and wipe afterwards with water. Do not use dry abrasive cleaners. This will scratch the PVC finish.
2. Clean any dirt build-up on the inside of the fittings and outside of the pipe ends. This will make it easier for insertion when assembling and removal when disassembling.
3. When storing frames it is best to rotate the rib sockets upside down. This prevents dirt and /or water from collecting in them.

The **rubber hammer** may be used when assembling and disassembling the counter's upper and lower supports.

CARE OF COUNTERS & SHELVES

1. **Clean with soap and water.** For stronger stains use a mild abrasive household cleaner such as Clorox Soft Scrub and wipe afterwards with water.
2. Do not sit items on the under counter shelf that will bulge or spill on the skirt. Center heavy items over the cross brace. Slide the cross brace towards the counter legs for maximum support.

LAYING CASES FLAT makes it easier to insert materials into the cases.