

Product Specifications

Viewable Graphic Size: 4' to 12' w x 1' to 5' h
 Graphic Finishing: Corner Grommets
 Color: White

Product Parts

- 1 - 6' Post w/Cap (x2)
- 2 - Eye Bolt (x4)
- 3 - Nut (x4)

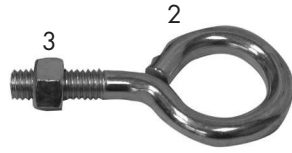

Spike Bottom



Display Set-Up

Step 1

Determine placement of the Posts (1) by adding at least 12" to 24" between the banner and post.

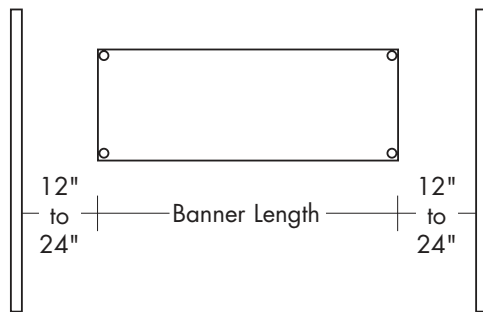

Step 2

Position the Posts (1) so that the large surface will face each other.

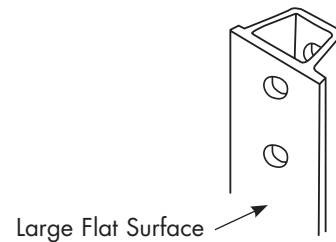

Step 3

With a standard Post Driver (Not Included), drive the Posts (1) into the ground. Repeat for the second Post (1).



Step 4

Determine the placement of the Eye Bolts (2) from the height of the banner. Thread two Eye Bolts (2) per Post (1) into the determined holes and finish them with a Nut (3).

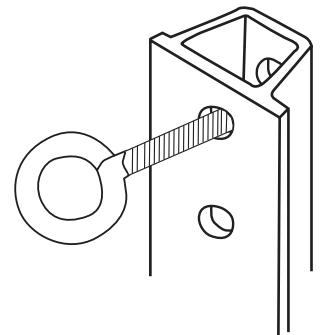

*Do not over tighten.

Step 5

Attach the Banner to the Eye Bolts (2) with Rope or Bungees (Not Included) and your display is complete.

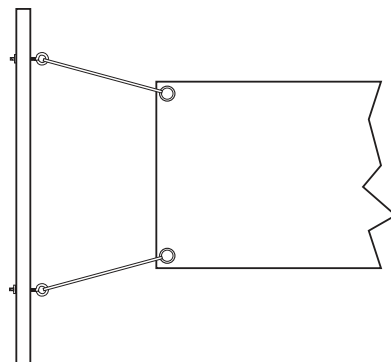

Storage

Place all product parts into shipping box and store in a cool, dry location.

Care

To clean, wipe with damp cloth.