

Formulate 12' Four Sided Tower - Illuminated

COL-01-BL

Mix and match the Formulate® line of towers to add architecture and drama to any event or interior space. Rectangular-shaped towers come in 12ft, 10ft and 8ft heights and 3ft square at the top and bottom. They combine the latest developments in fabric printed technology with aluminum tube frames to add dimension, decor and sculpture to any event, stage set, tradeshow booth or interior space. Formulate towers accommodate internal LED lighting to create a glowing effect.



features and benefits:

- State-of-the-art 30mm aluminum tube frame with snap button assembly
- Easy to store and ship
- Tool-less assembly
- Quick to set up
- Kit includes: one frame, one dye-sublimated zipper pillowcase graphic, internal lighting components and and one wheeled storage case
- Lifetime hardware warranty against manufacturer defects

dimensions:

Hardware

Graphic

Assembled unit:
36" w x 144" h x 36" d
915mm(w) x 3658mm(h) x 915mm(d)

Refer to related graphic template for more information.

Approximate weight:
40 lbs / 19 kg

Shipping

additional information:

Packing case(s):
1 OCL

Graphic material:
Dye-sublimation zipper pillowcase fabric

Shipping dimensions:
OCL:
56" l x 19" h x 19" d
1422mm(l) x 483mm(h) x 483mm(d)

When included in a larger kit, a different packaging solution will be listed to accommodate all contents of the kit. Individual packaging no longer provided.

Approximate weight:
60 lbs / 28 kg

LIGHT-HANGING-CABLE:
Caution, the internal lighting power cable is at its maximum power output with 6 light bulbs, do not add additional light bulbs to it. Replace these light bulbs with same watt type.

Included In Your Kit

Components, Connectors & Graphic



TC-30-3W x8



COL-T1 x6



COL-T2 x8



COL-T3 x2



COL-T4 x8



COL-T5 x4



COL-01-BL-T6 x1



WC-30T x2



LIGHT-HANGING-CABLE x1



LIGHT-HANGING-EXTENSION-20 x1



LIGHT-HANGING-EXTENSION-32 x1



LIGHT-HANGING-EXTENSION-38 x1



LIGHT-HANGING-5WAY-SOCKET x2



LIGHT-HANGING-BULB x6



COL-01-BL-G x1

Exploded View

COL-01-BL

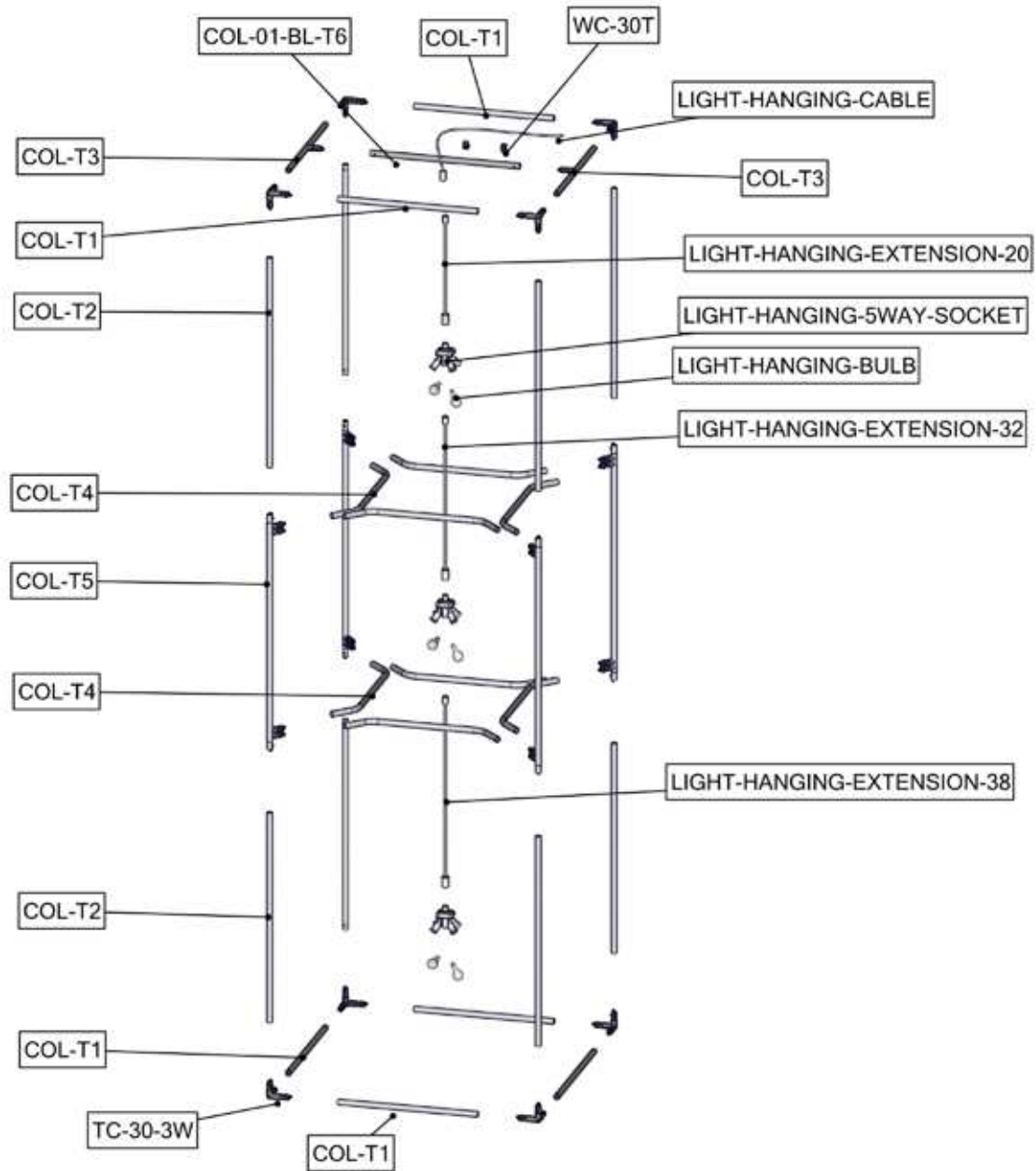

Labeling Diagram

COL-01-BL

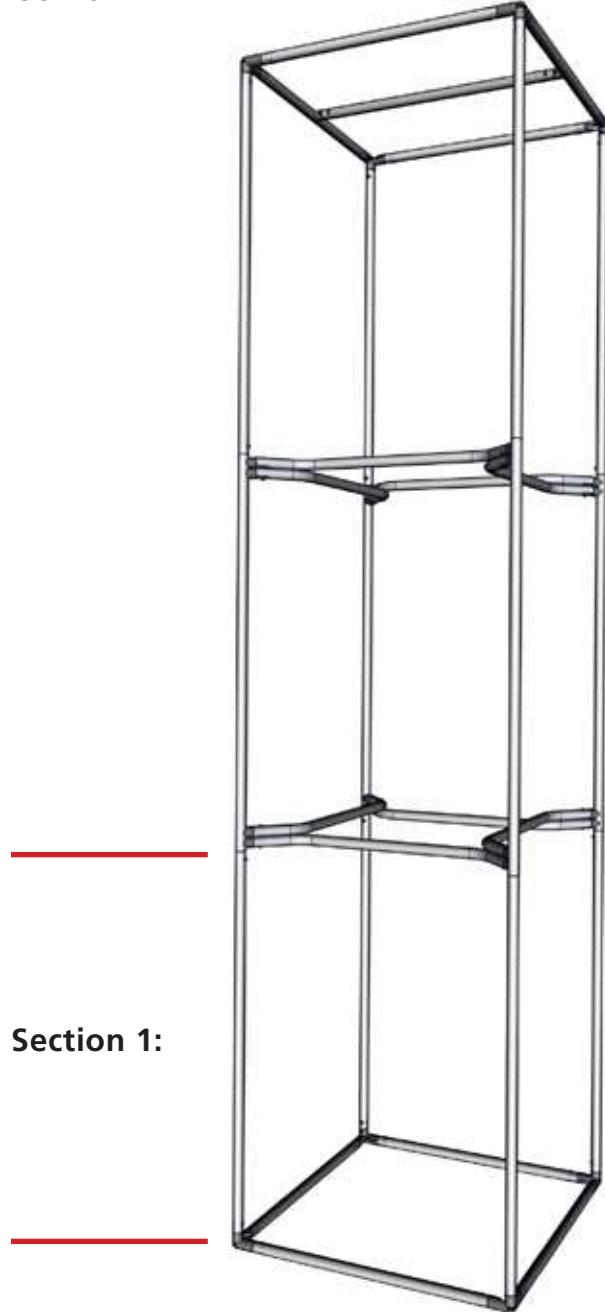

Section 1:

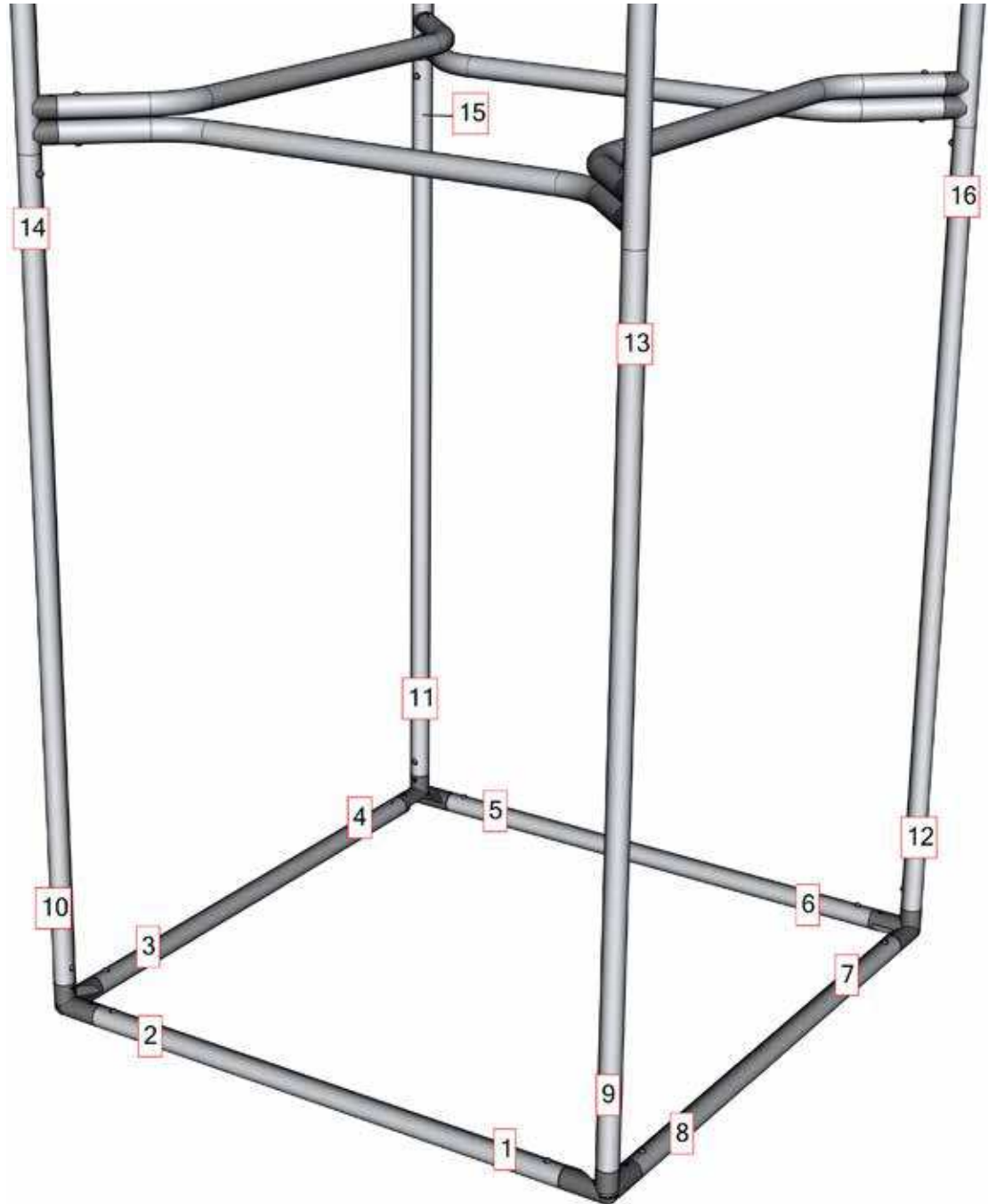

Labeling Diagram

COL-01-BL

Section 2:

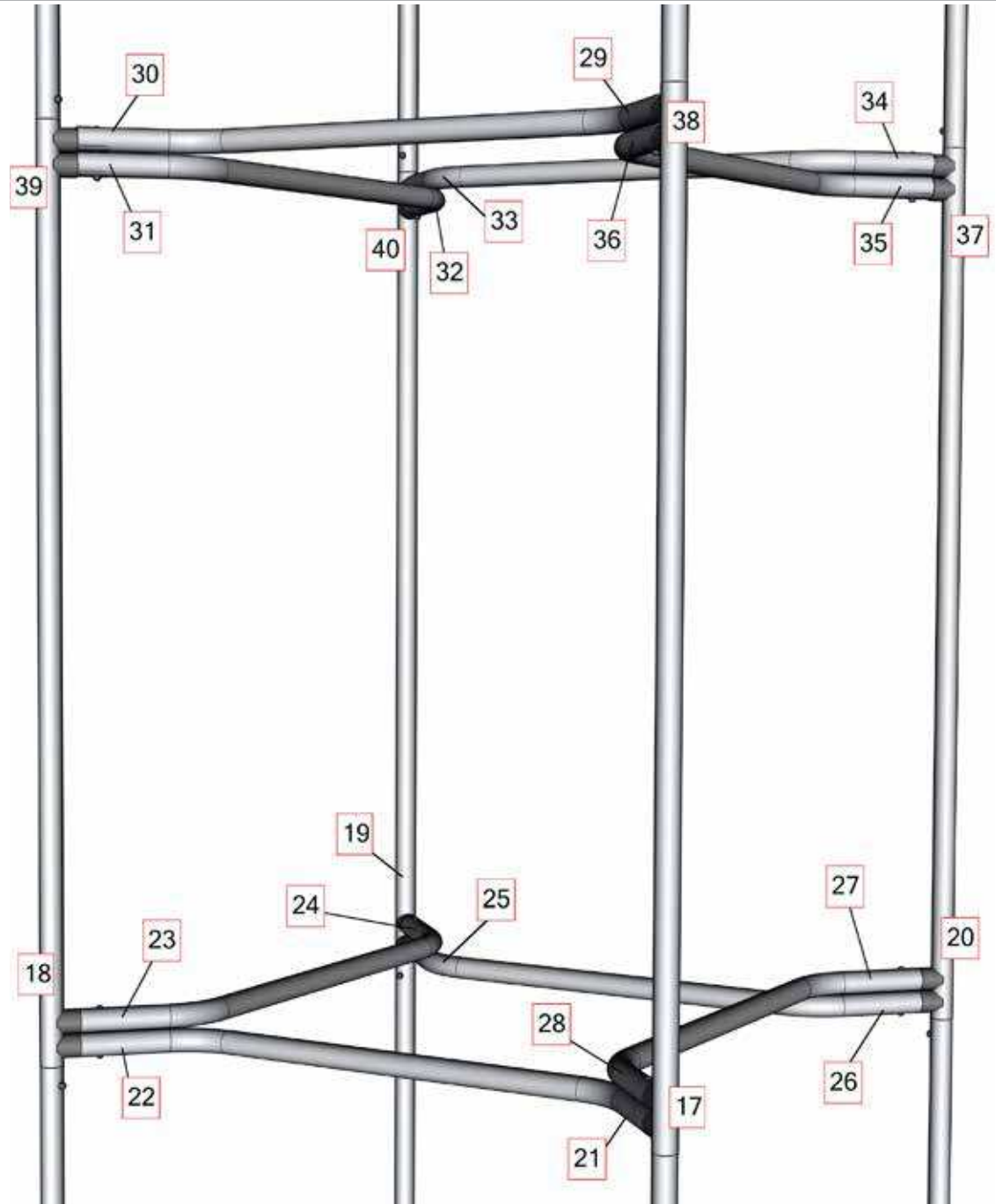
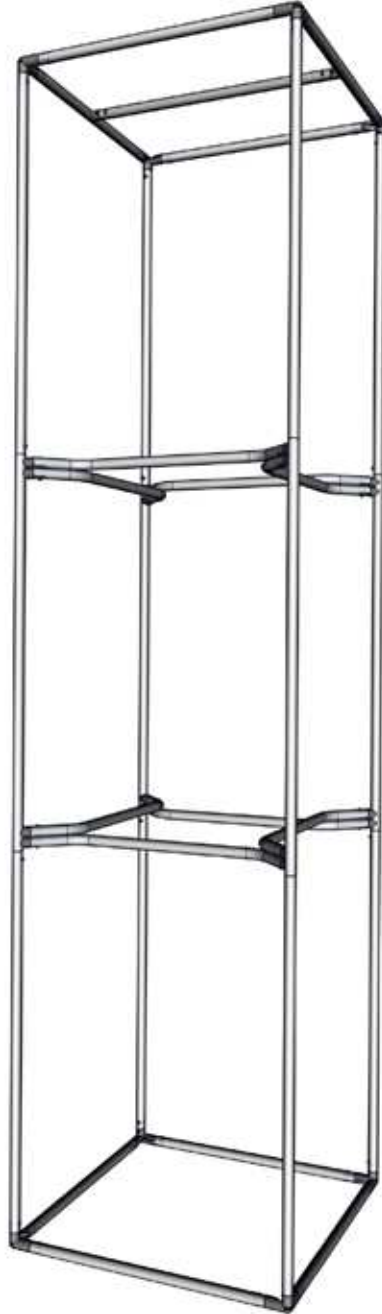

Labeling Diagram

COL-01-BL



Section 3:

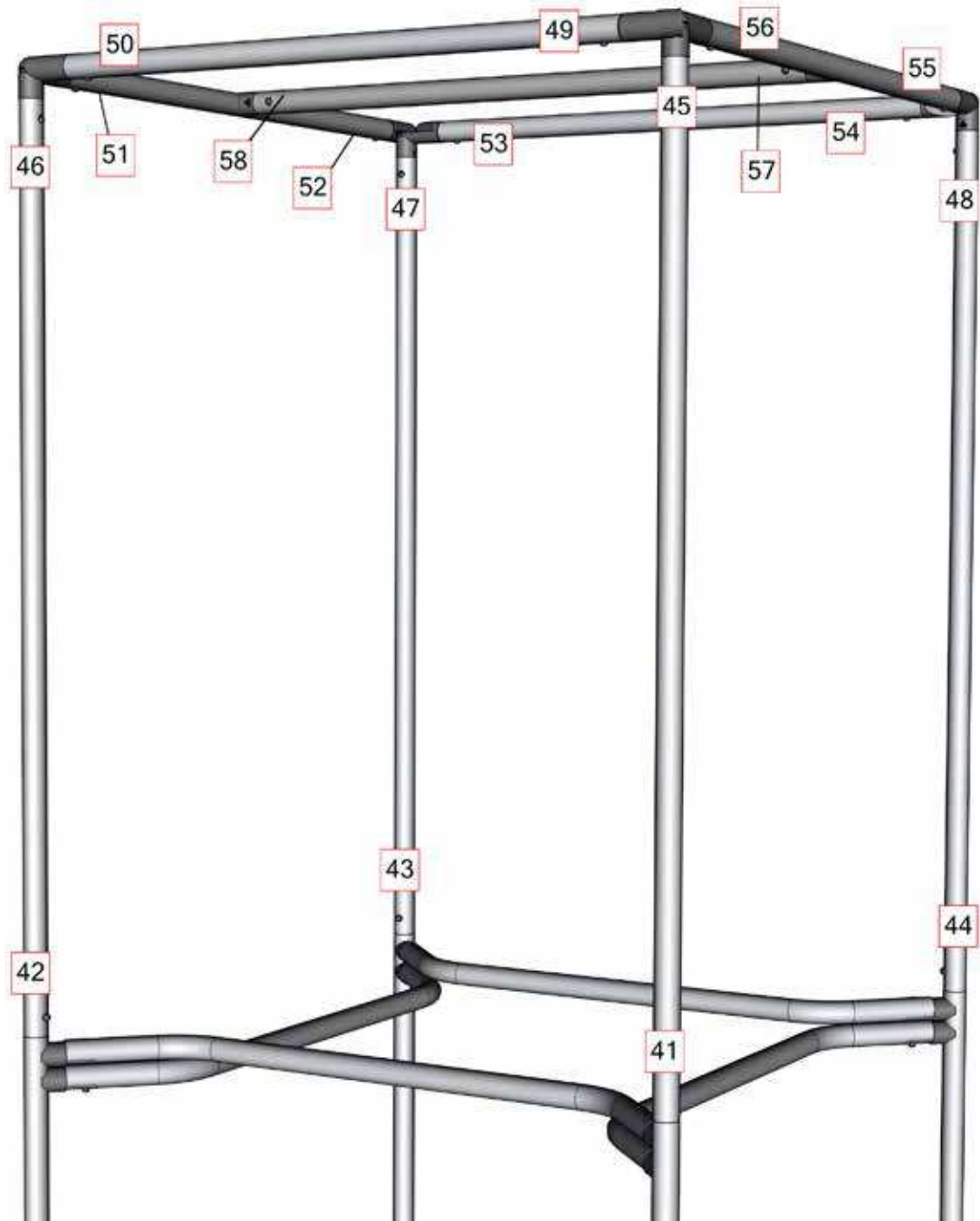

Connection Methods

Connection Method 1: SNAP BUTTONS

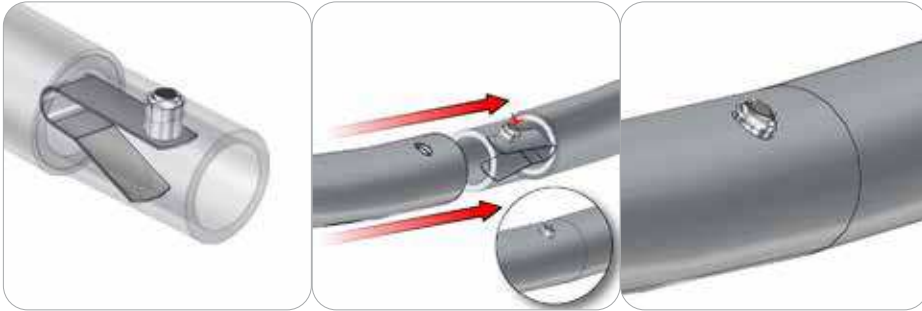

Snap button connections are simple and easy to use. First, locate the snap button on the connector or swage tube. Second, locate the hole on the corresponding tube. Press the snap button with your thumb and slide the tube and connector together so that the snap button snaps fully into the hole. To disassemble, press the snap button and carefully pull them apart.

Connection Method 2: WC-30T

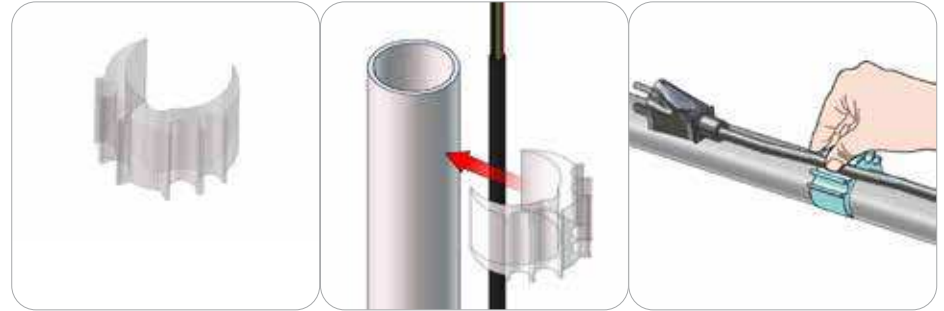

First, press the wire clamp over the power cord to sandwich it onto the tube. The inside of the wire clamp only supports one power cord. Second, once the wire clamp is in place, use the four slots to hold up to 4 power cables.

Connection Method 3: TC-30-3W

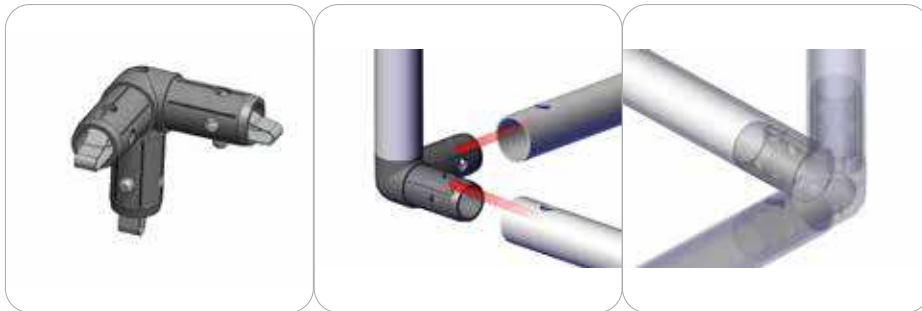

Snap button connections are simple and easy to use. First, locate the snap button on the connector or swage tube. Second, locate the hole on the corresponding tube. Press the snap button with your thumb and slide the tube and connector together so that the snap button snaps fully into the hole. To disassemble, press the snap button and carefully pull them apart.

Kit Assembly

Step by Step

Step 1.

Gather the components to build Section 1 of the tower frame. Use the Exploded View and the Labeling Diagram for part labels.

Reference Connection Methods 1 & 3 for more details.



Step 2.

Gather the components to build Section 2 of the tower frame. Use the Exploded View and the Labeling Diagram for part labels.

Reference Connection Method 1 for more details.



Step 3.

Gather the components to build Section 3 of the tower frame. Use the Exploded View and the Labeling Diagram for part labels.

Reference Connection Methods 1 & 3 for more details.



Step 4.

Lay the three sections flat on floor. Combine them to complete the tower frame assembly. Use the Exploded View and the Labeling Diagram for part labels.

Reference Connection Method 1 for more details.

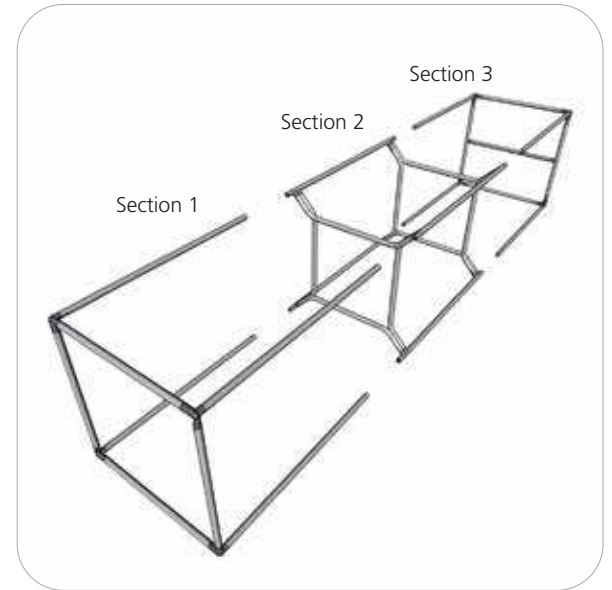

Kit Assembly

Step by Step

Step 5.

Leave the tower frame flat on floor. Undo the zipper pillow case and pull it over the top of the tower. Work the pillowcase down to the bottom of the frame and leave it un-zippered.

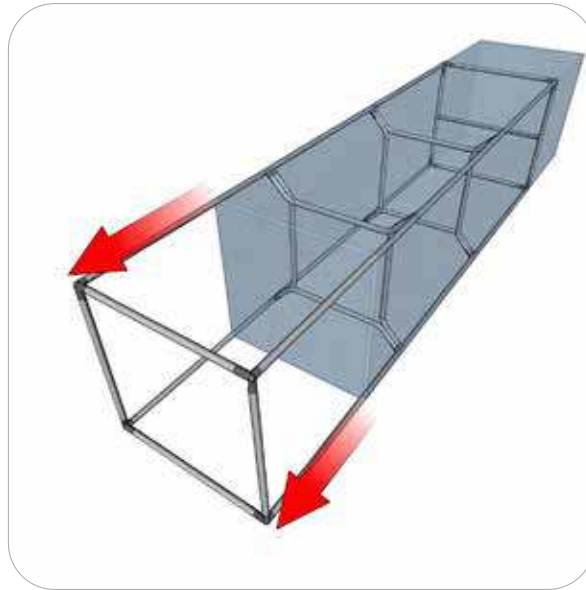

Step 6.

With the pillowcase open, gather the components for installing the internal lighting of the tower. Use the Exploded View for part labels. These components simply hang from tube #6 at the top of the frame and power cable runs down and out of the bottom opening. Close the zippers and carefully stand the tower upright.

Reference Connection Method 2 for more details.

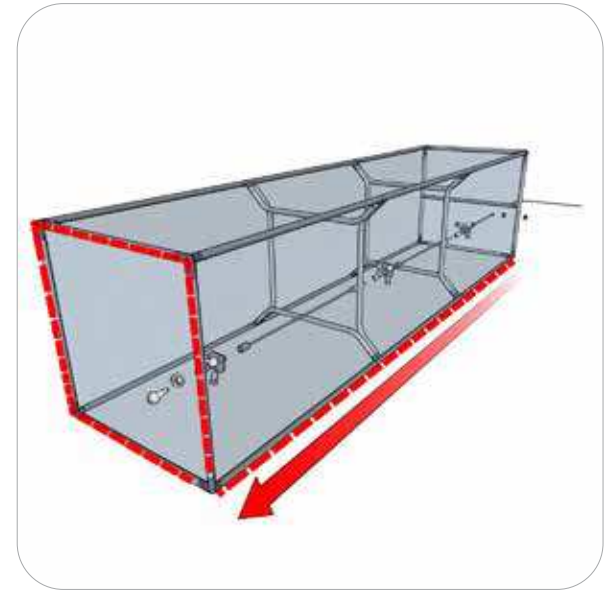

Step 7.

Once the unit is upright, test the power connection to the lights. Adjust for minimizing shadowing and hot spots.

Setup is complete.

