

MODify Double Sided Kit 01

MODify™ is a one-of-a-kind Modular Merchandising System that is made up of interchangeable fixtures and accessories that can be easily assembled, disassembled, and rearranged to create a variety of different display configurations. The MODify system incorporates SEG push-fit fabric graphics that enable you to brand, promote and merchandise with ease.

MODify Double Sided Kit 01 provides ample retail merchandise display space with its two-sided slatwall design. The push-fit fabric header enables the display of branding, promotions, or product identification. Easily configure with casters, shelves, Ubars, slatwall hooks and other fixtures.



We are continually improving and modifying our product range and reserve the right to vary the specifications without prior notice. All dimensions and weights quoted are approximate and we accept no responsibility for variance. E&OE. See Graphic Templates for graphic bleed specifications

features and benefits:







Base Kit includes:

- Frame, slatwall, shelf and base colors in kit are all the same, your choice of all white, black, or silver
- Heavy-duty aluminum frame, steel base
- Steel, slotted uprights
- Double sided 35"W x 72"H slatwall display
- Frame topper with 35"W x 12"H SEG push-fit graphic, one on each side
- Base (casters are optional)
- Display is easy to assemble and install
- Lifetime hardware warranty against manufacturer defects

Optional Accessories Include:

- Casters.
- U bars
- Slatwall hooks
- Shelves
- Towel bars
- Faceout bars
- Waterfalls

dimensions:

Hardware	Shipping
<p>Assembled unit:</p> <p>37.5"W x 72"H x 37.5"D 952.5mm(w) x 1828.8mm(h) x 952.5mm(d)</p> <p>Approximate Weight: 103 lbs / 46.72 kg</p>	<p>Packing case(s): 1 Box</p> <p>Shipping dimensions: (62"L x 14"H x 24"D) 1574.8mm(l) x 355.6mm(h) x 609.6mm(d)</p> <p>Approximate shipping weight: 155 lbs / 70.3068 kg</p>
Graphics	additional information:
<p>Graphic material: Dye-sublimated fabric</p> <p>See graphic templates for graphic sizes.</p> <p>Refer to related graphic templates for more information Visit: https://www.theexhibitorshandbook.com/downloads/download-graphic-templates or click here</p>	<p>Powder coat color options:</p> <div style="display: flex; justify-content: space-around; align-items: center;"> <div style="text-align: center;"> white</div> <div style="text-align: center;"> black</div> <div style="text-align: center;"> silver</div> </div> <p>Wood laminate color options:</p> <div style="display: flex; justify-content: space-around; align-items: center;"> <div style="text-align: center;"> white</div> <div style="text-align: center;"> black</div> <div style="text-align: center;"> natural</div> <div style="text-align: center;"> gray</div> </div>

MODify Accessories

All Accessories available in white, black, or silver

Slotwall Accessories



MFY-SLT-HK
4", 6", 8", 10" & 12"



MFY-SLT-FC
6", 8", 10" & 12"

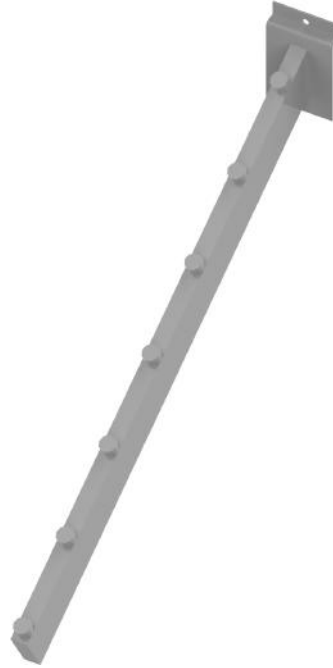

MFY-SLT-WTR-16-7

U-Bar Accessories



MFY-TWL-FC
6", 8" & 10"



MFY-UBR-FC
6", 8" & 10"



MFY-CSTR-4-PK

Shelf and Hanger Bars

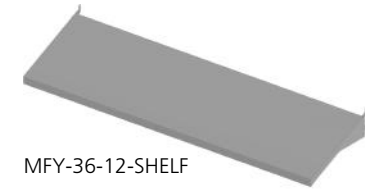

MFY-36-12-SHELF

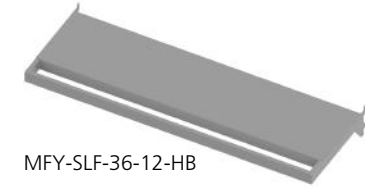

MFY-SLF-36-12-HB

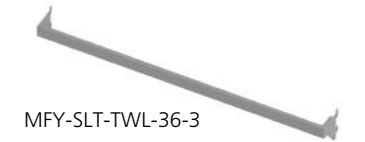

MFY-SLT-TWL-36-3

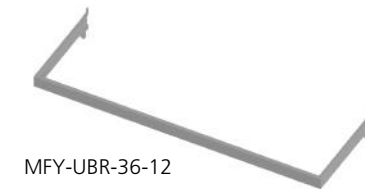

MFY-UBR-36-12

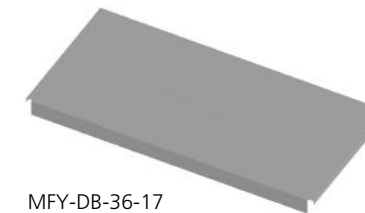

MFY-DB-36-17

Tools Required



MULTI HEX KEY
(INCLUDED)



PHILLIPS SCREW DRIVER
(NOT INCLUDED)



9/16" SOCKET WRENCH
(NOT INCLUDED)

How to Apply & Remove Graphics

Installation and removal of SEG graphics is easy!

Installation: Push the SEG bead into each corner of the frame (1-4) with your thumb, then push the SEG bead into the middle of the run (5-8) and work your way around the perimeter of the frame until all beading is pushed in properly; if necessary, go around the perimeter again to ensure beading is secure in the extrusion profile.

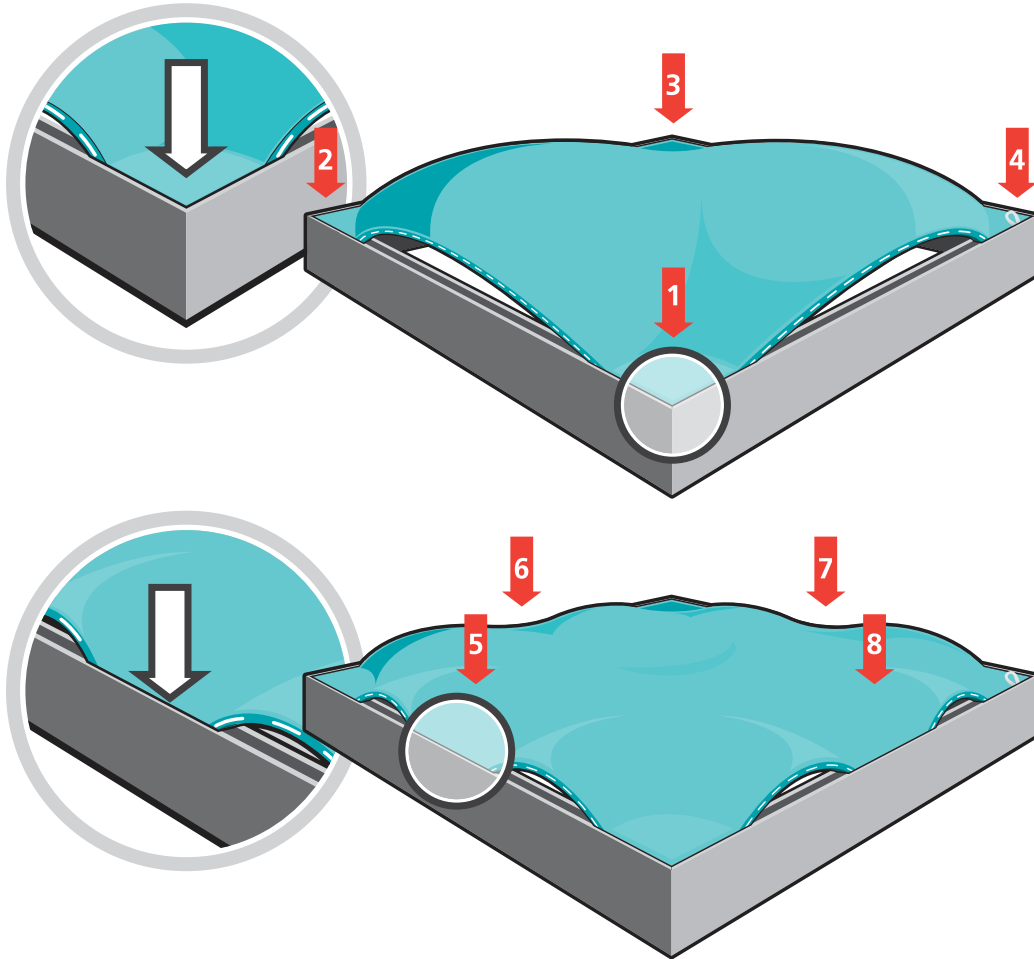





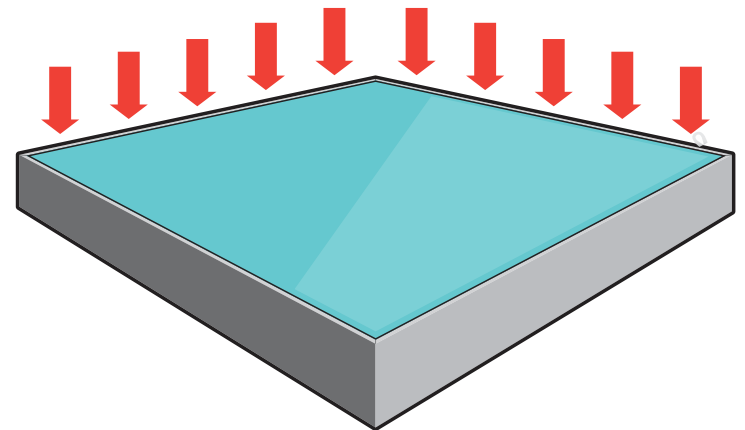

Note: Keep the set up area clean by using a drop cloth, washing hands before set-up or by wearing gloves.

Removal: Use the pull tab located on the graphic and gently pull the graphic from the frame, going around the perimeter.



Graphics Storage & Care

Graphics should be folded with the graphic facing inward and stored in a zip lock /sealable plastic bag. Spot clean by wiping with a damp white cloth. If washing is necessary, use a commercial size front-loading washing machine, gentle cycle with cool water. Line dry flat. Dry cleaning is NOT recommended to prevent shrinkage.

QTY	IMAGE	DESCRIPTION
2		3/8-16 x 2.5" L bolt
1		1435MM (56.50in) LEFT UPRIGHT
1		1435MM (56.50in) RIGHT UPRIGHT
1		947MM (37.28IN) LENGTH OF 824 RIGHT SUPPORT LEG
1		947MM (37.28IN) LENGTH OF 824 LEFT SUPPORT LEG
2		1335MM (52.56in) OF SWC EXTRUSION

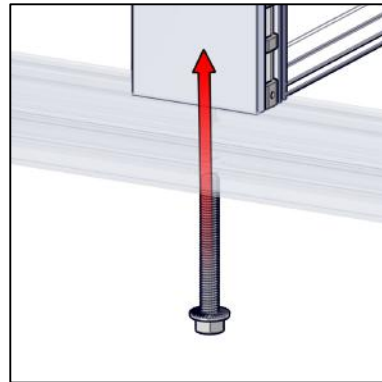
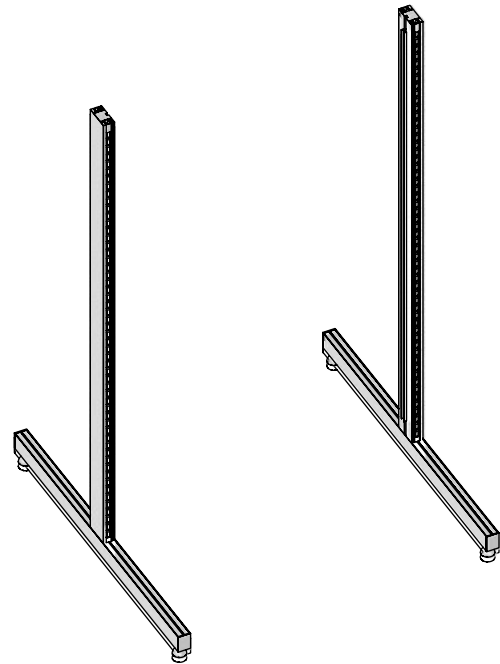

MFY-BOLT-375-16-2.5

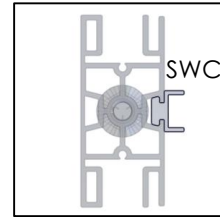
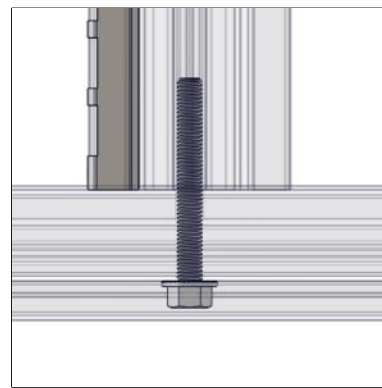

LEFT UPRIGHT

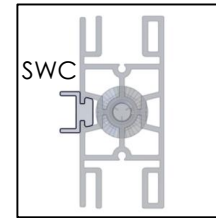

SETUP INSTRUCTIONS

RIGHT UPRIGHT

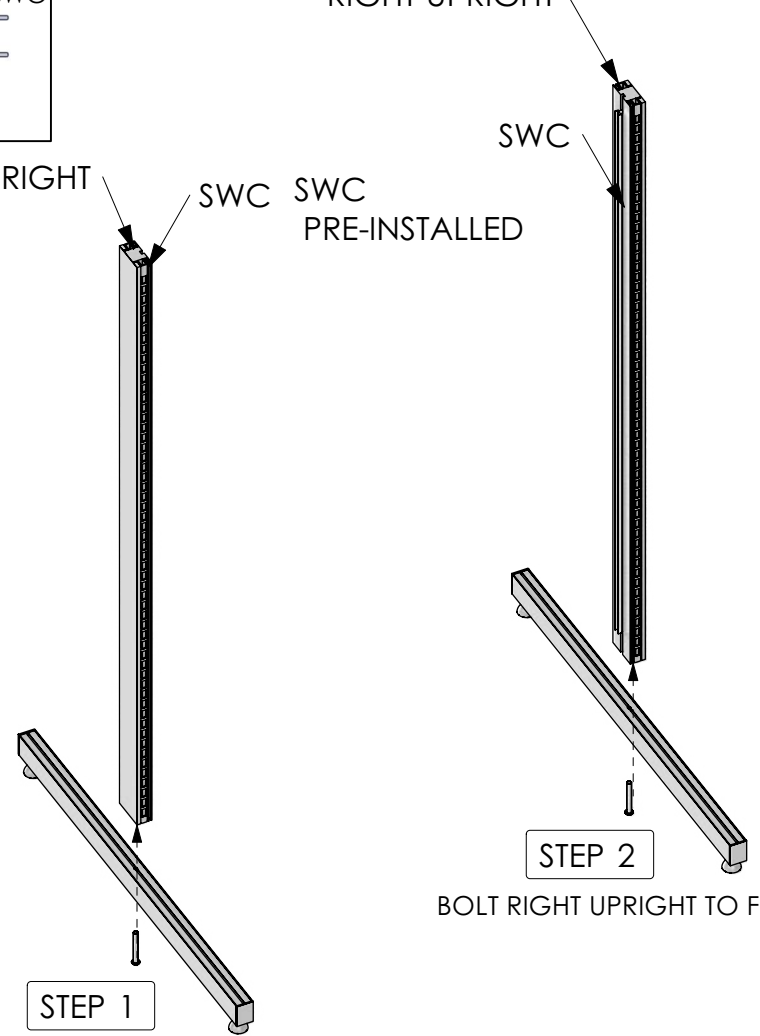

STEP 1

BOLT LEFT UPRIGHT TO FOOT

STEP 2

BOLT RIGHT UPRIGHT TO FOOT

SETUP INSTRUCTIONS

QTY	IMAGE	DESCRIPTION
1		883MM (34.76in) OF SINGLE SIDED SEG EXTRUSION -WITH CAM LOCKS BOTH ENDS
1		883MM (34.76in) OF SWC EXTRUSION

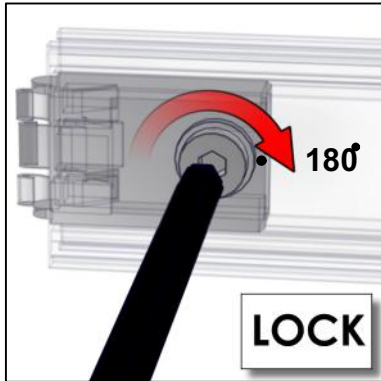

IMPORTANT! MAKE A HALF TURN
TO LOCK EXTRUSIONS

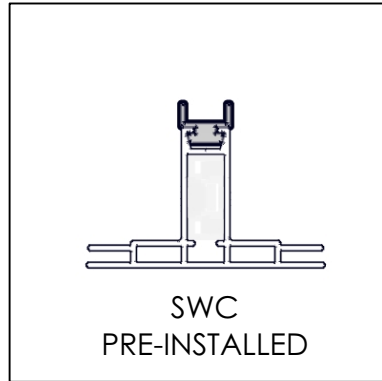

SLOT WALL TOP CHANNEL

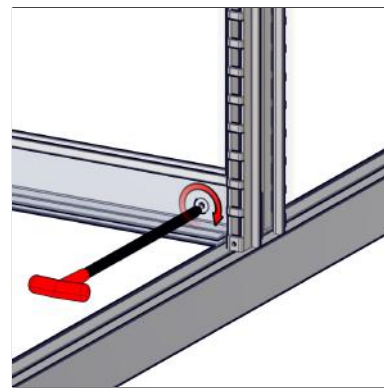
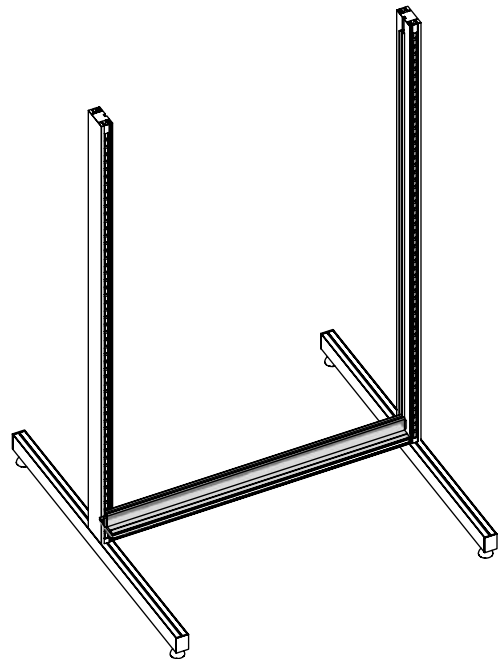

CROSS BRACE SITS
ON SUPPORT LEGS

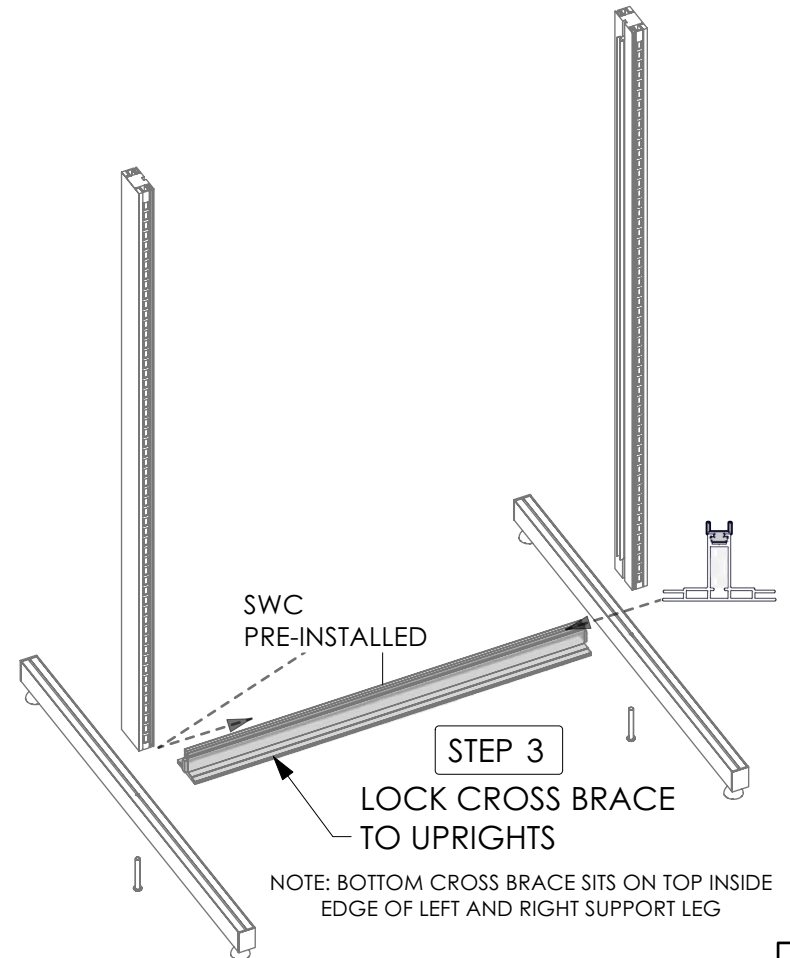



SWC
PRE-INSTALLED

STEP 3

LOCK CROSS BRACE
TO UPRIGHTS

NOTE: BOTTOM CROSS BRACE SITS ON TOP INSIDE
EDGE OF LEFT AND RIGHT SUPPORT LEG

QTY	IMAGE	DESCRIPTION
8		879MM (34.61in) LENGTH OF SLOTWALL EXTRUSION
1		879MM (34.61in) LENGTH OF SLOTWALL EXTRUSION -WITH 29MM BOTTOM CUT

SETUP INSTRUCTIONS

STEP 4

SLOTWALL EXTRUSION STACK 005-879

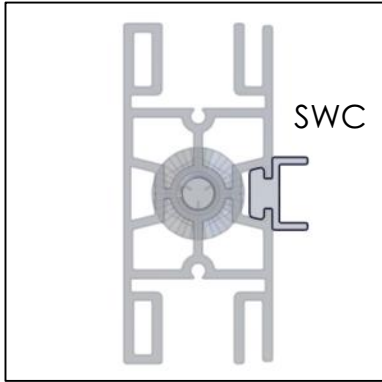

SLOTWALL CHANNEL

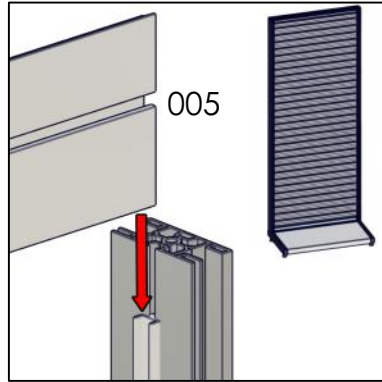

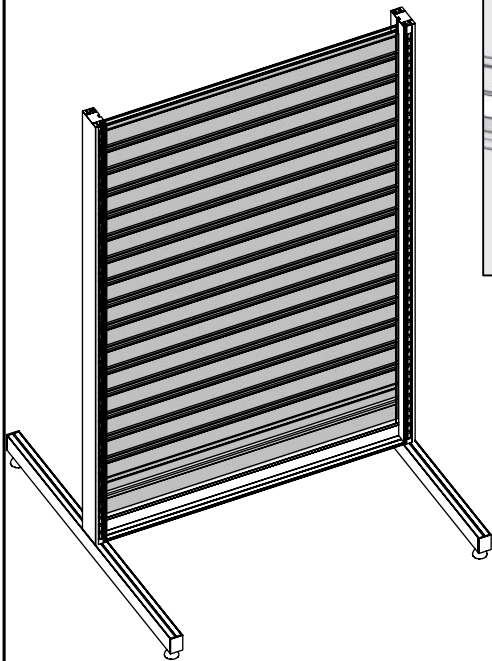
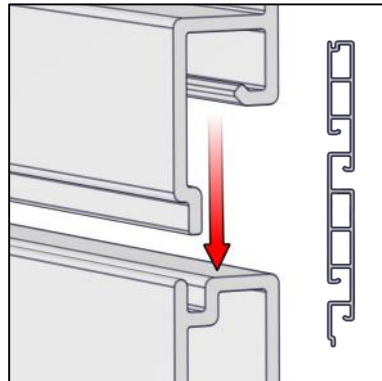

SLOTWALL EXTRUSION

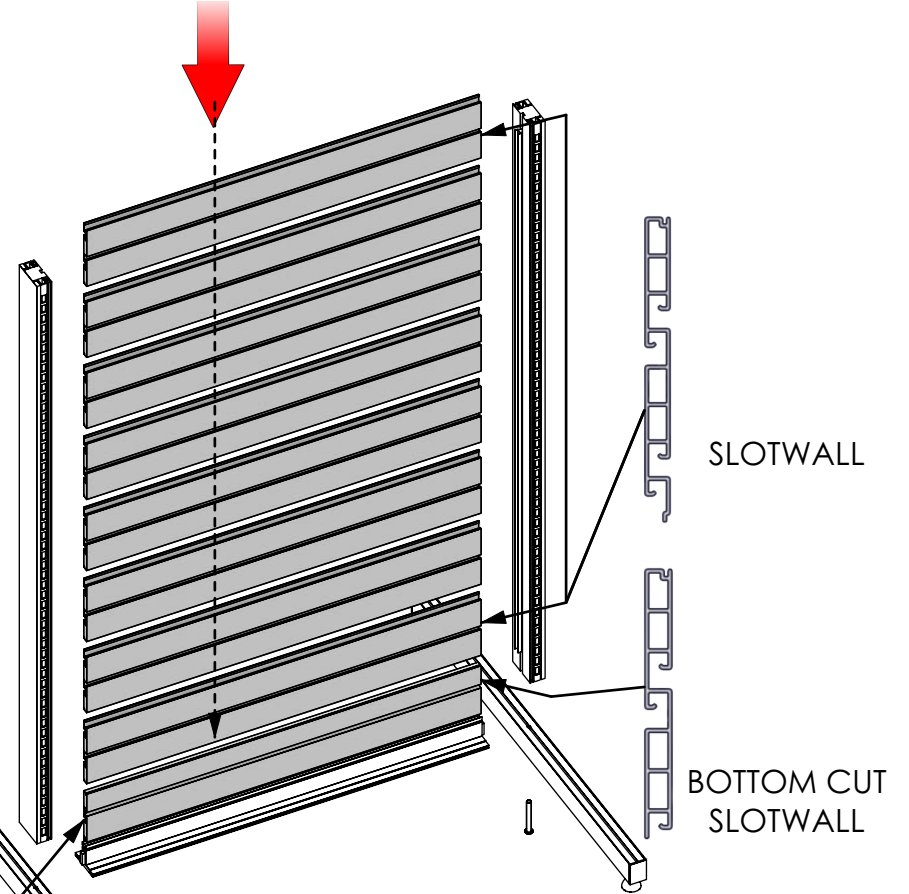

INSTALL
5" TALL
EXTRUSION
FIRST



SETUP INSTRUCTIONS

1		883MM (34.76in) OF SINGLE SIDED SEG EXTRUSION -WITH CAM LOCKS BOTH ENDS WITH TWO HOLES
1		883MM (34.76in) OF SINGLE SIDED SEG EXTRUSION -WITH CAM LOCKS BOTH ENDS
2		7MM SEG PLASTIC END CAP FOR 833 EXTRUSION

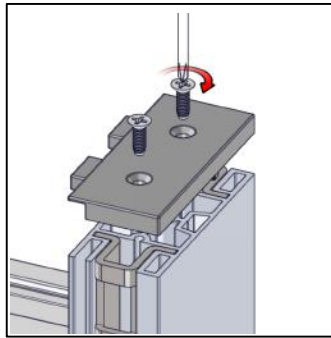

LOOSEN END CAP TO ATTACH TOP CROSS BRACE

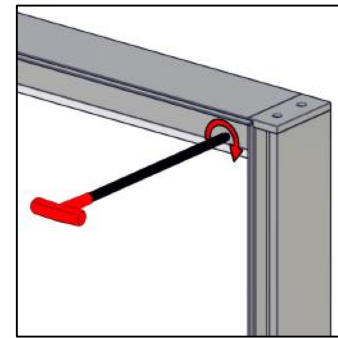

STEP 5

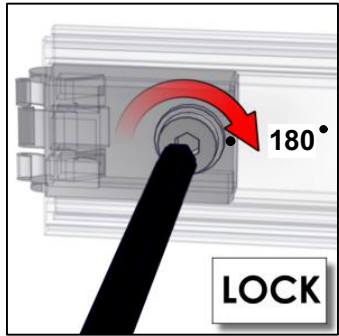

LOCK

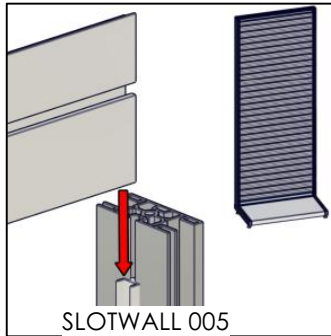
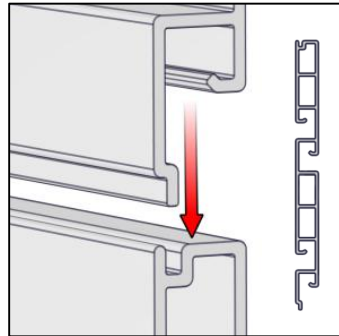

SLOTWALL 005

IMPORTANT!
MAKE A HALF TURN
TO LOCK EXTRUSIONS

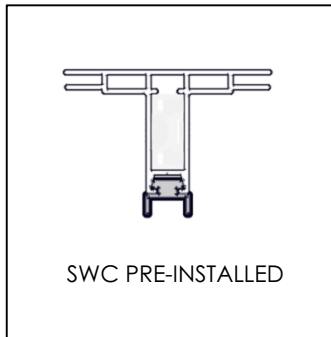

SWC PRE-INSTALLED

SLOT WALL BOTTOM CHANNEL

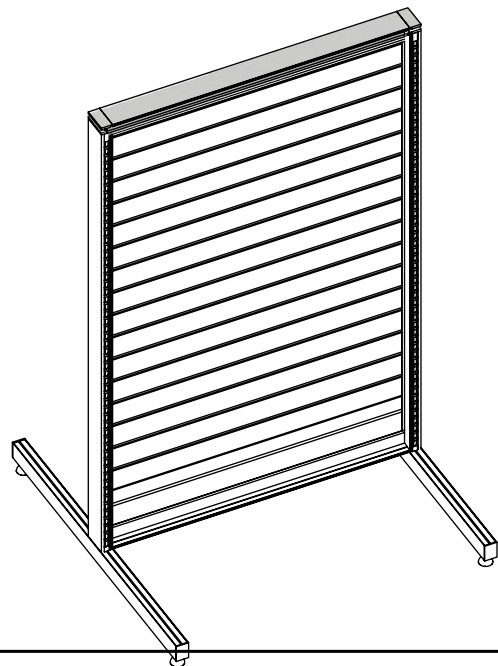
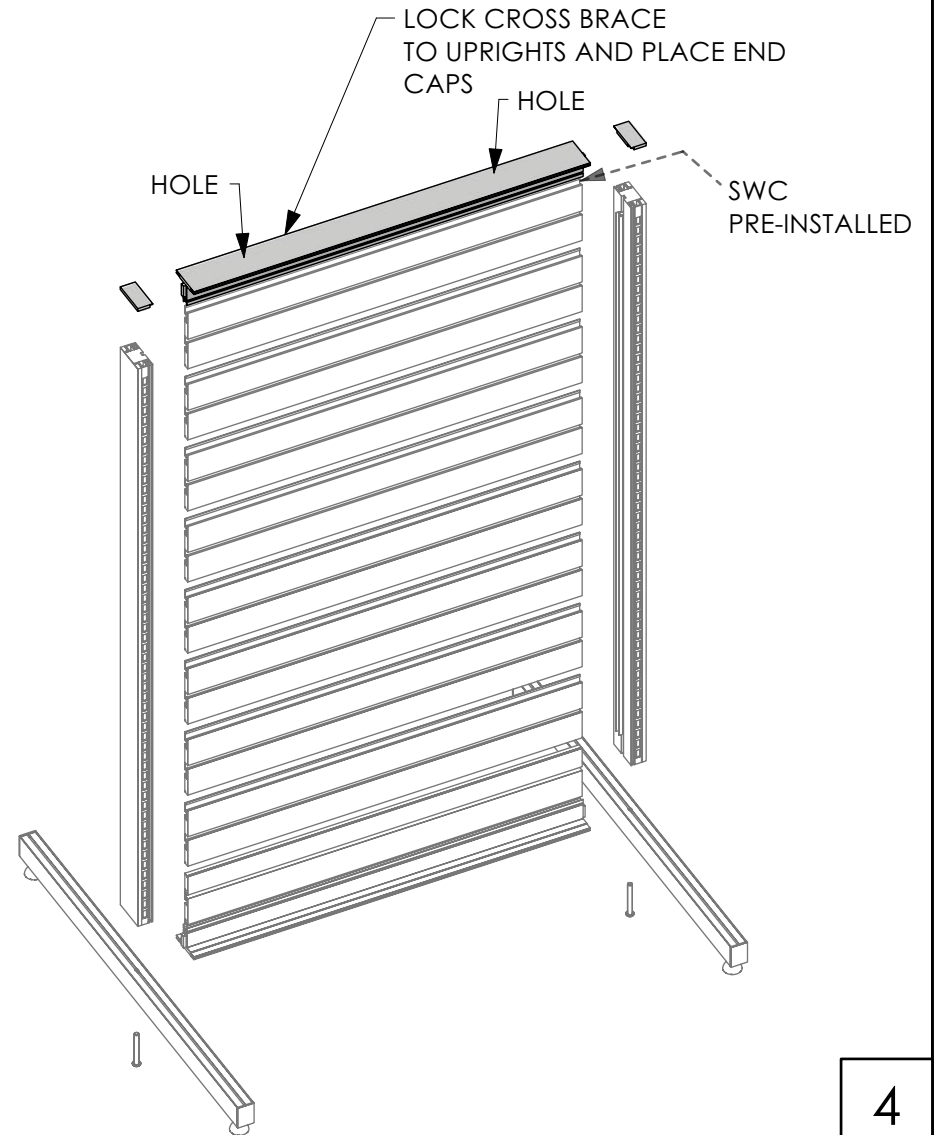

QTY	IMAGE	DESCRIPTION
1		883MM (34.7in) LENGTH OF WMFCD EXTRUSION 45 DEGREE MITER CUT BOTH ENDS
1		883MM (34.7in) LENGTH OF WMFCD EXTRUSION 45 DEGREE MITER CUT BOTH ENDS WITH TWO HOLES
4		SINGLE VECTOR CORNER CLEAT
2		305MM (12.01in) LENGTH OF WMFCD EXTRUSION 45 DEGREE MITER CUT BOTH ENDS
2		1/4"-20 x 1"L bolt

SETUP INSTRUCTIONS

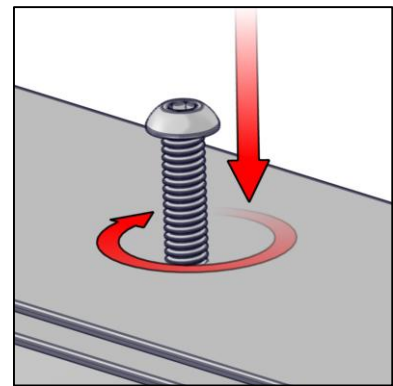

STEP 7
BOLT TOP FRAME
TO CROSS BRACE

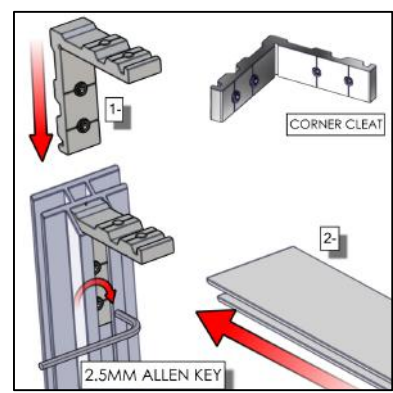

CORNER CLEAT

STEP 6
ASSEMBLE TOP
FRAME

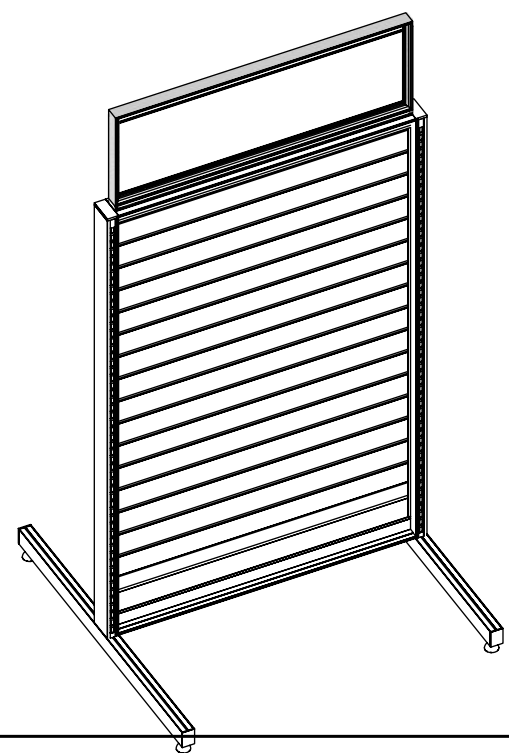
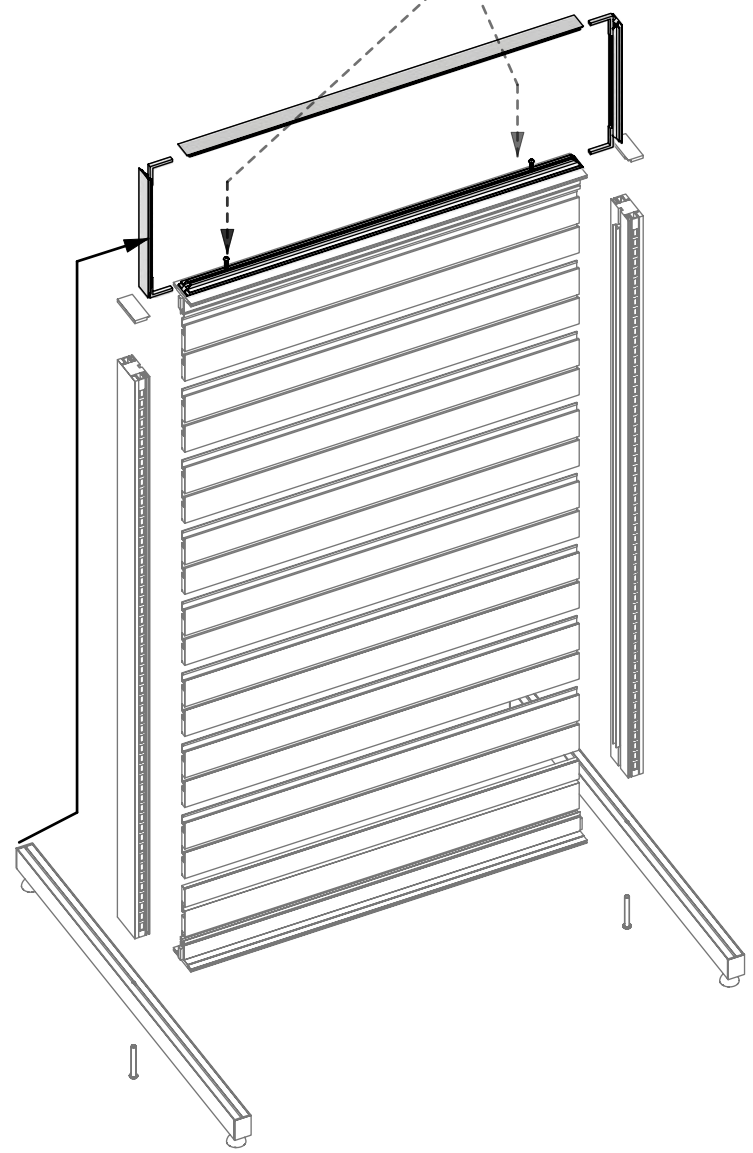

CODE	#	DESCRIPTION
005-879	8	879MM (34.61in) LENGTH OF SLOTWALL EXTRUSION
005-879	1	879MM (34.61in) LENGTH OF SLOTWALL EXTRUSION -WITH 29MM BOTTOM CUT

SETUP INSTRUCTIONS

STEP 8

INSTALL GRAPHICS

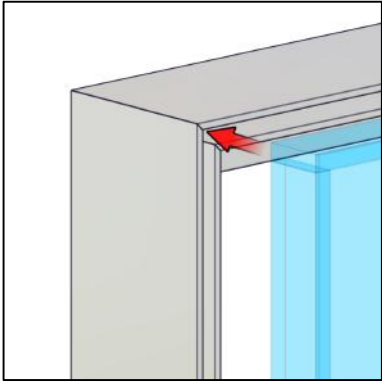

PRESS GRAPHIC INTO CORNERS

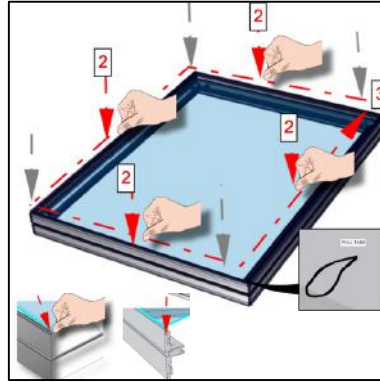

THEN PRESS ALONG THE PERIMETER EDGE

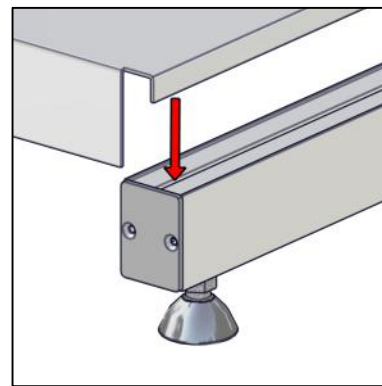
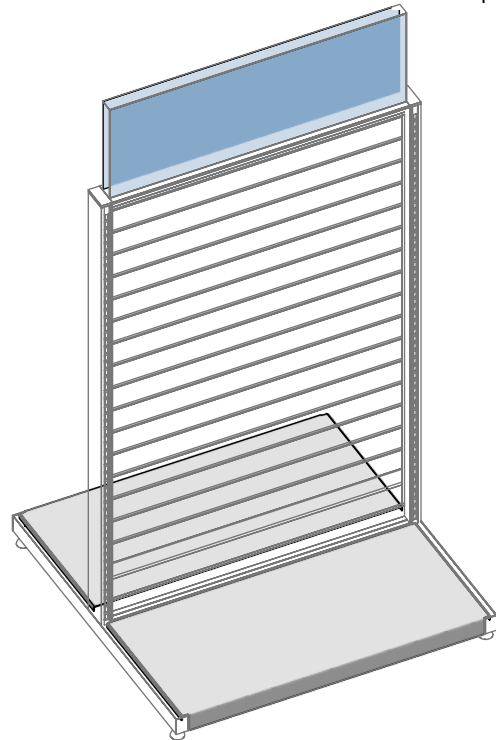



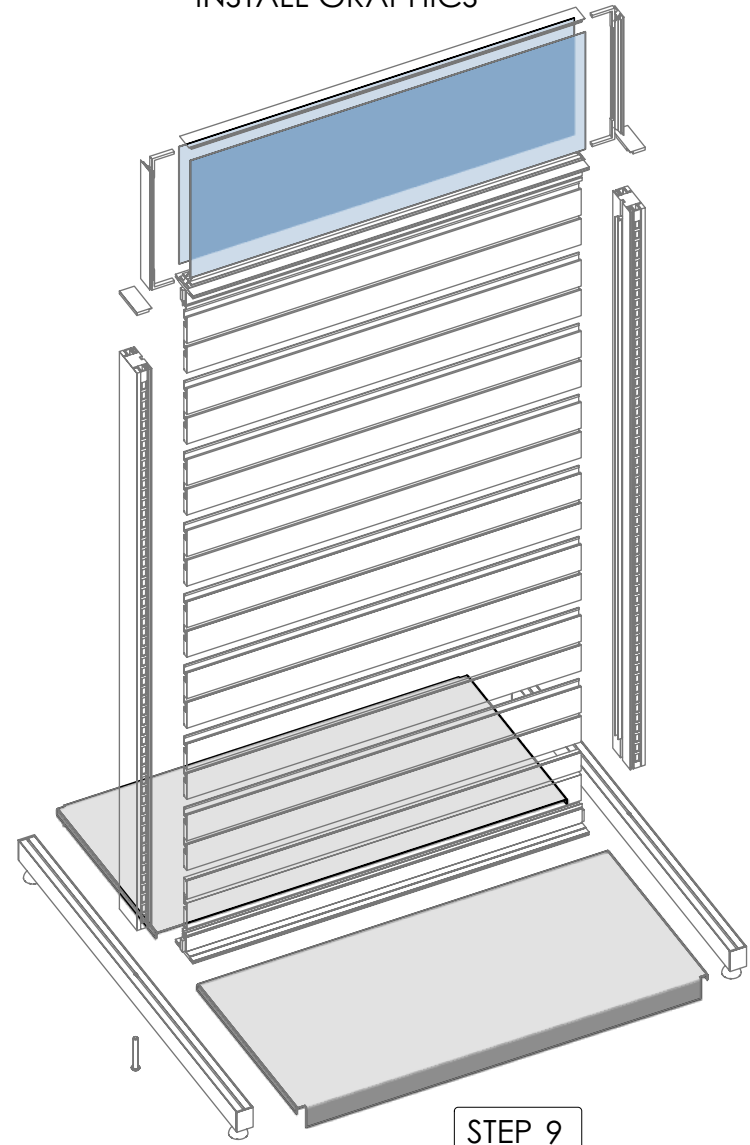















MFY-36-17-BASE-PAN





STEP 9

PLACE BASE PAN IN GROOVE(FOOT)

Kit Hardware BOM

ITEM	COMPONENTS	QTY	DESCRIPTION
	004-883	1	883MM (34.76in) OF SINGLE SIDED SEG EXTRUSION -WITH CAM LOCKS BOTH ENDS
	004-883	1	883MM (34.76in) OF SWC EXTRUSION
	004-1335	2	1335MM (52.56in) OF SWC EXTRUSION
	005-879	8	879MM (34.61in) LENGTH OF SLOTWALL EXTRUSION
	005-879	1	879MM (34.61in) LENGTH OF SLOTWALL EXTRUSION -WITH 29MM BOTTOM CUT
	306-305-15-15	2	305MM (12.01in) LENGTH OF WMFCD EXTRUSION 45 DEGREE MITER CUT BOTH ENDS
	306-883-15-15	1	883MM (34.76in) LENGTH OF WMFCD EXTRUSION 45 DEGREE MITER CUT BOTH ENDS
	306-883-15-15	1	883MM (34.76in) LENGTH OF WMFCD EXTRUSION 45 DEGREE MITER CUT BOTH ENDS WITH TWO HOLES
	824-947	1	947MM (37.28IN) LENGTH OF 824 LEFT SUPPORT LEG
	824-947	1	947MM (37.28IN) LENGTH OF 824 RIGHT SUPPORT LEG
	833-1435	1	1435MM (56.50in) LEFT UPRIGHT
	833-1435	1	1435MM (56.50in) RIGHT UPRIGHT
	833-EC	2	7MM SEG PLASTIC END CAP FOR 833 EXTRUSION
	835-883-01-01	1	883MM (34.76in) OF SINGLE SIDED SEG EXTRUSION -WITH CAM LOCKS BOTH ENDS
	835-883-01-01	1	883MM (34.76in) OF SINGLE SIDED SEG EXTRUSION -WITH CAM LOCKS BOTH ENDS WITH TWO HOLES
	MFY-BOLT-.25-20-1	2	1/4"-20 x 1"L bolt
	MFY-BOLT-375-16-2.5	2	3/8-16 x 2.5"L bolt
	MFY-DB-36-17	2	36in WIDE X 17.25in DEEP - DROP-IN BASE PAN
	VF-CC	4	SINGLE VECTOR CORNER CLEAT

Kit Graphics BOM

ITEM	COMPONENTS	QTY	DESCRIPTION
	MFY-DS-01-A-G	1	(38.65 w X 15.88 h total size) 34.65 w X 11.88 h finish size, Dye-sub print on Eclipse Blockout Stretch, single sided, sewn with FCE-2 silicone beading around perimeter & pull tab in bottom right corner
	MFY-DS-01-B-G	1	(38.65 w X 15.88 h total size) 34.65 w X 11.88 h finish size, Dye-sub print on Eclipse Blockout Stretch, single sided, sewn with FCE-2 silicone beading around perimeter & pull tab in bottom right corner