

# MODify Double Sided Kit 03

MODify™ is a one-of-a-kind Modular Merchandising System that is made up of interchangeable fixtures and accessories that can be easily assembled, disassembled, and rearranged to create a variety of different display configurations. The MODify system incorporates SEG push-fit fabric graphics that enable you to brand, promote and merchandise with ease.

MODify Double Sided Kit 03 is so flexible! One side includes an SEG graphic panel that allows for color, promotion and messaging; six shelves are included. The other side is open and intended for hanging apparel. This display is an ideal choice for retailers looking to create a visually stunning and efficient display.



We are continually improving and modifying our product range and reserve the right to vary the specifications without prior notice. All dimensions and weights quoted are approximate and we accept no responsibility for variance. E&OE. See Graphic Templates for graphic bleed specifications

## features and benefits:

Base Kit includes:

- Frame, slatwall, shelf and base colors in kit are all the same, your choice of all white, black, or silver
- Heavy-duty aluminum frame, steel base
- Steel, slotted uprights
- Side panel features SEG push-fit fabric graphics & six shelves, three shelves on each side
- Open section used to hang apparel and merchandise
- Base (casters are optional)
- Display is easy to assemble and install
- Lifetime hardware warranty against manufacturer defects

Optional Accessories Include:

- Towel bars.
- U bars
- Faceout bars
- Casters

## dimensions:

### Hardware

Assembled unit:

74"W x 72"H x 37.5"D  
1879.6mm(w) x 1828.8mm(h) x 952.5mm(d)

Approximate Weight:  
136 lbs / 61.6886 kg

### Shipping

Packing case(s):  
1 Box

Shipping dimensions:  
(72"L x 22"H x 24"D)  
1828.8mm(l) x 558.8mm(h) x 609.6mm(d)

Approximate shipping weight:  
196 lbs / 88.9041 kg

## additional information:

### Graphics

Graphic material: Dye-sublimated fabric

See graphic templates for graphic sizes.

Refer to related graphic templates for more information Visit:

<https://www.theexhibitorshandbook.com/downloads/download-graphic-templates>  
or click here

Powder coat color options:



Wood laminate color options:



# MODify Accessories

All Accessories available in white, black, or silver

## Slotwall Accessories



MFY-SLT-HK  
4", 6", 8", 10" & 12"



MFY-SLT-FC  
6", 8", 10" & 12"

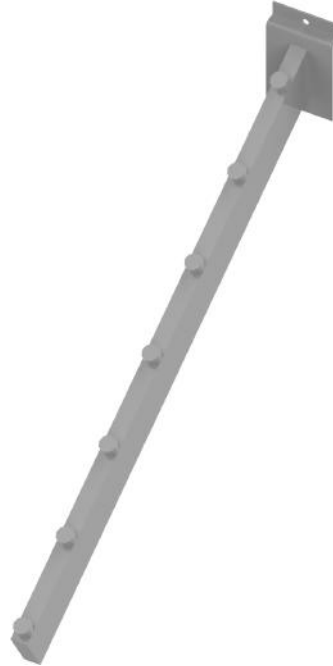

MFY-SLT-WTR-16-7

## U-Bar Accessories



MFY-TWL-FC  
6", 8" & 10"



MFY-UBR-FC  
6", 8" & 10"



MFY-CSTR-4-PK

## Shelf and Hanger Bars

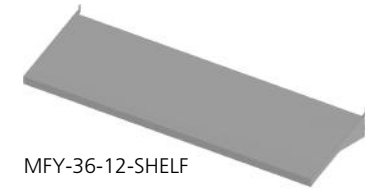

MFY-36-12-SHELF

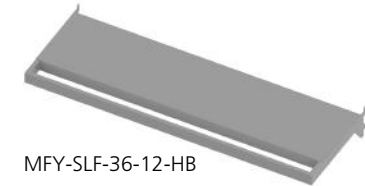

MFY-SLF-36-12-HB

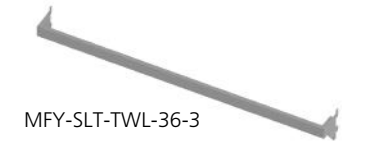

MFY-SLT-TWL-36-3

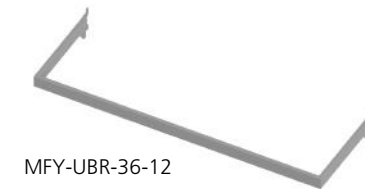

MFY-UBR-36-12

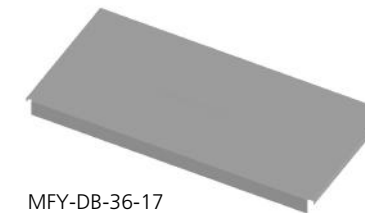

MFY-DB-36-17

# Tools Required



MULTI HEX KEY  
(INCLUDED)



PHILLIPS SCREW DRIVER  
(NOT INCLUDED)



9/16" SOCKET WRENCH  
(NOT INCLUDED)

## How to Apply & Remove Graphics

Installation and removal of SEG graphics is easy!

**Installation:** Push the SEG bead into each corner of the frame (1-4) with your thumb, then push the SEG bead into the middle of the run (5-8) and work your way around the perimeter of the frame until all beading is pushed in properly; if necessary, go around the perimeter again to ensure beading is secure in the extrusion profile.

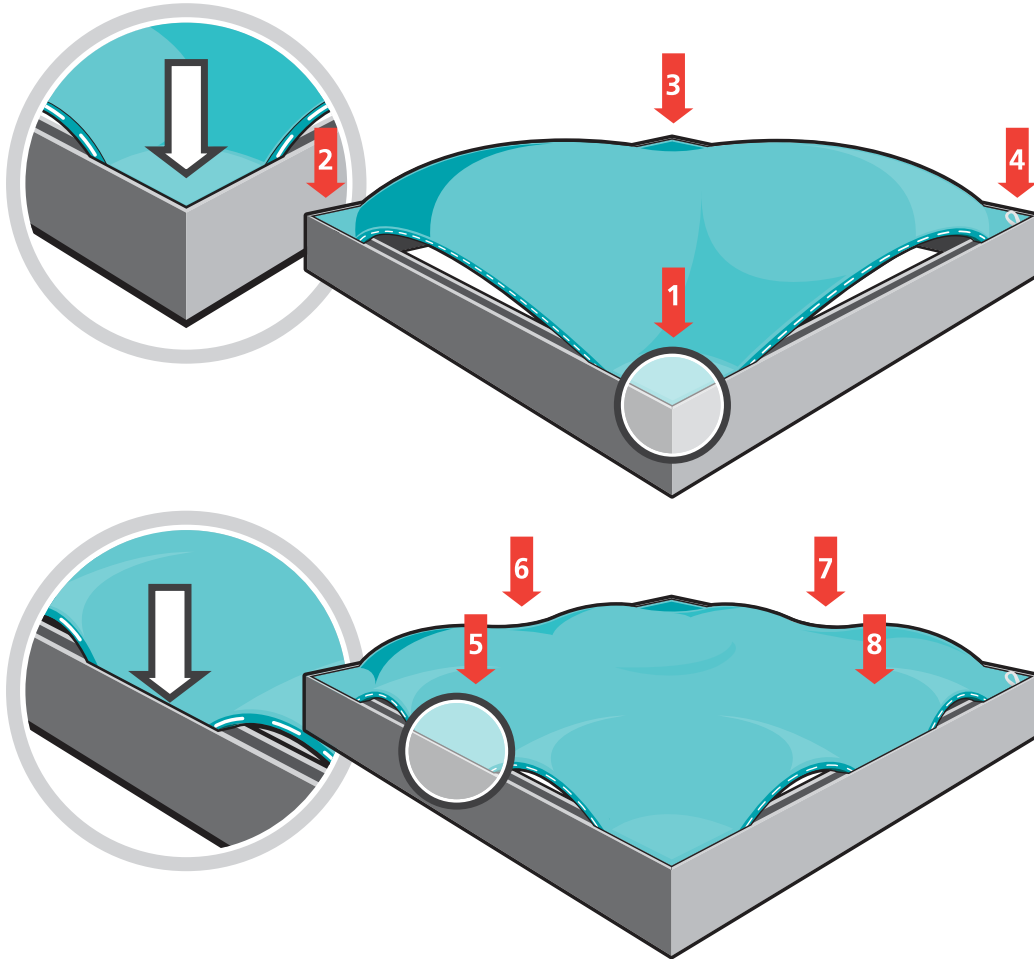





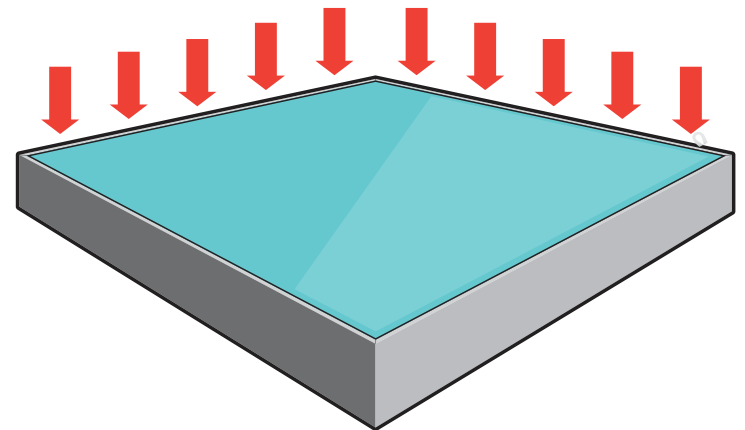

**Note:** Keep the set up area clean by using a drop cloth, washing hands before set-up or by wearing gloves.

**Removal:** Use the pull tab located on the graphic and gently pull the graphic from the frame, going around the perimeter.



## Graphics Storage & Care

Graphics should be folded with the graphic facing inward and stored in a zip lock /sealable plastic bag. Spot clean by wiping with a damp white cloth. If washing is necessary, use a commercial size front-loading washing machine, gentle cycle with cool water. Line dry flat. Dry cleaning is NOT recommended to prevent shrinkage.

QTY	IMAGE	DESCRIPTION
3		3/8-16 x 2.5-3"L bolt
1		1740MM (68.50in) MIDDLE UPRIGHT
1		1740MM (68.50in) LEFT UPRIGHT
1		947MM (37.28IN) MIDDLE SUPPORT LEG
1		947MM (37.28IN) LEFT SUPPORT LEG
1		947MM (37.28IN) RIGHT SUPPORT LEG
1		1740MM (68.50in) RIGHT UPRIGHT

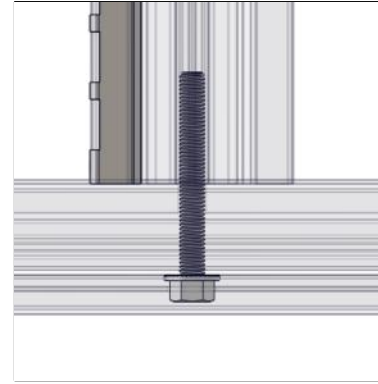
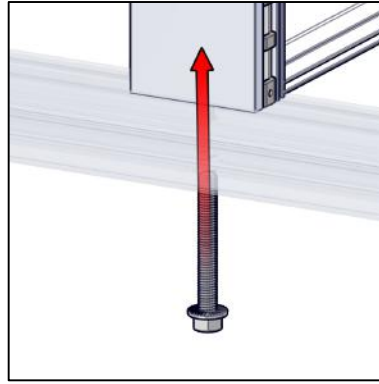

MFY-BOLT-375-16-2.5

## SETUP INSTRUCTIONS

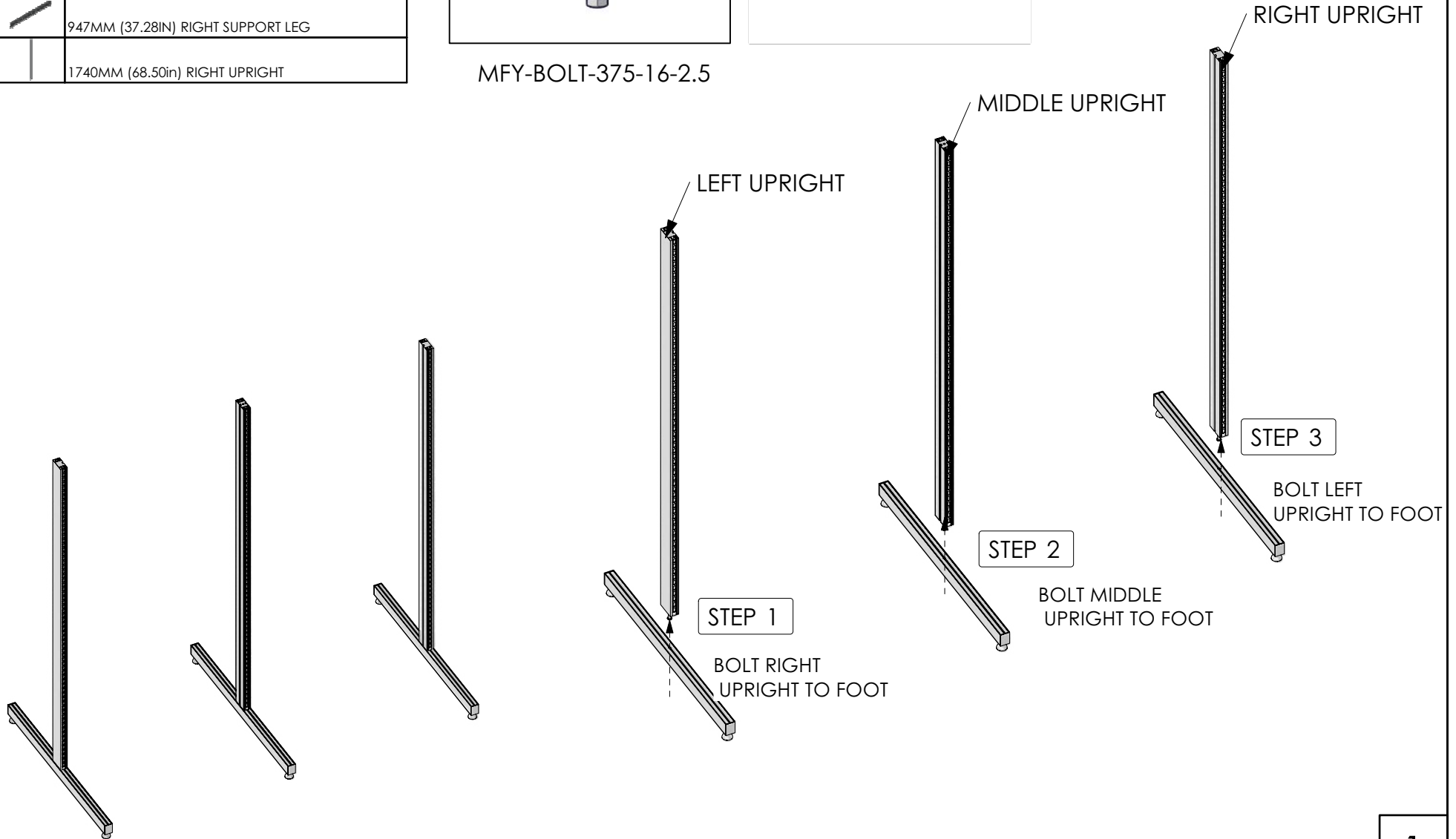

QTY	IMAGE	DESCRIPTION
4		883MM (34.76in) OF SINGLE SIDED SEG EXTRUSION WITH CAM LOCKS BOTH ENDS
1		883MM LENGTH OF PH1 EXTRUSION WITH CAM LOCKS BOTH ENDS
2		7MM SEG PLASTIC END CAP FOR 833 EXTRUSION
1		7MM SEG PLASTIC END CAP FOR 832 EXTRUSION

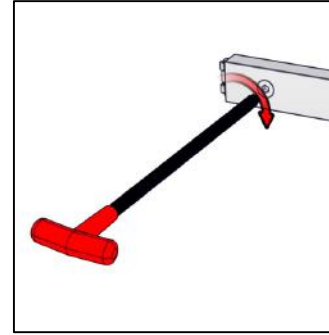
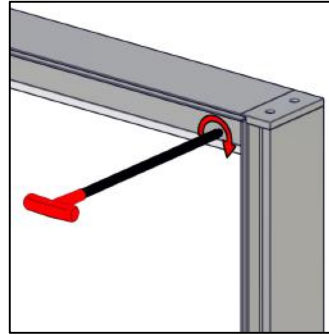

## SETUP INSTRUCTIONS

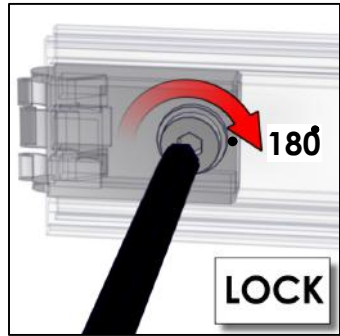

IMPORTANT!  
MAKE A HALF TURN  
TO LOCK EXTRUSIONS

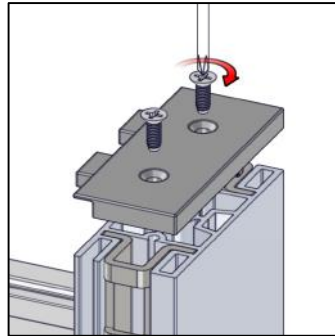

LOOSEN END CAP TO ATTACH  
TOP CROSS BRACE

### STEP 7

LOCK CROSS BRACE  
TO UPRIGHTS AND PLACE END  
CAPS

### STEP 8

LOCK CROSS BRACE  
TO UPRIGHTS AND PLACE END  
CAPS

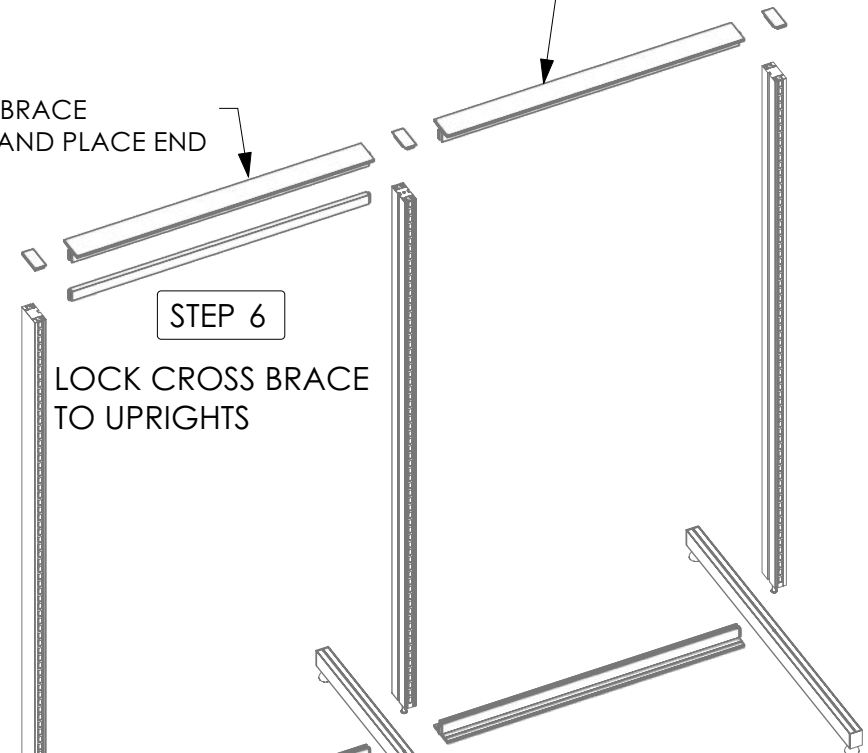

### STEP 6

LOCK CROSS BRACE  
TO UPRIGHTS

### STEP 5

LOCK CROSS BRACE  
TO UPRIGHTS

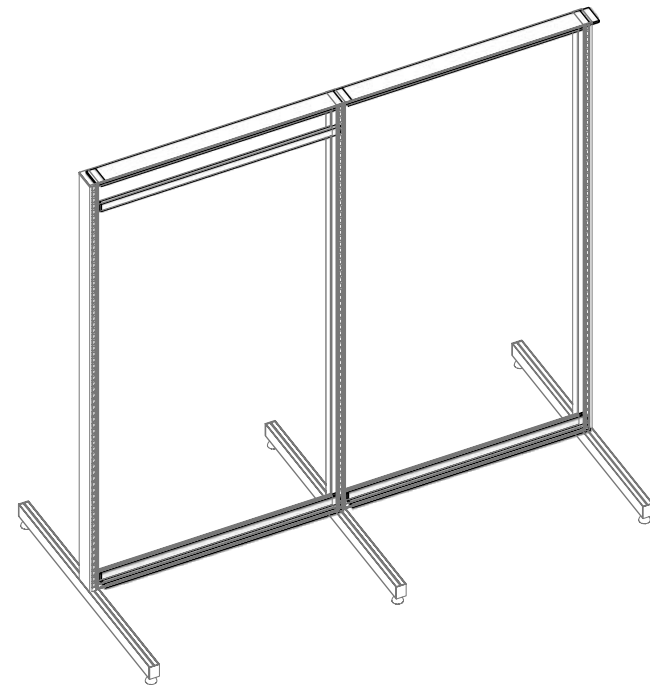

### STEP 4

LOCK CROSS BRACE  
TO UPRIGHTS

NOTE: BOTTOM CROSS BRACE SITS ON TOP INSIDE  
EDGE OF LEFT AND RIGHT SUPPORT LEG

QTY	IMAGE	DESCRIPTION
2		(39.26 w X 72.60 h total size ) 35.26 w X 68.60 h finish size, Dye-sub print on Eclipse Blockout Stretch, single sided, sewn with FCE-2 silicone beading around perimeter & pull tab in bottom right corner (WITH 1/4" NOTCH LEFT & RIGHT BOTTOM HORIZONTAL SIDE CORNERS)

## SETUP INSTRUCTIONS

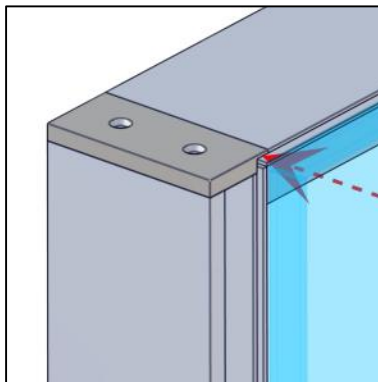

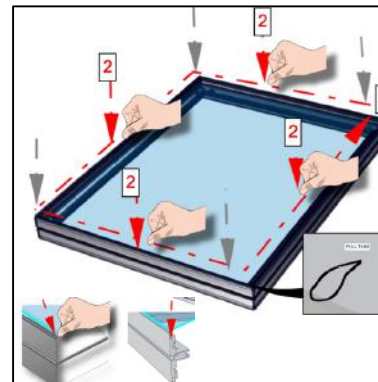

PRESS GRAPHIC INTO CORNERS

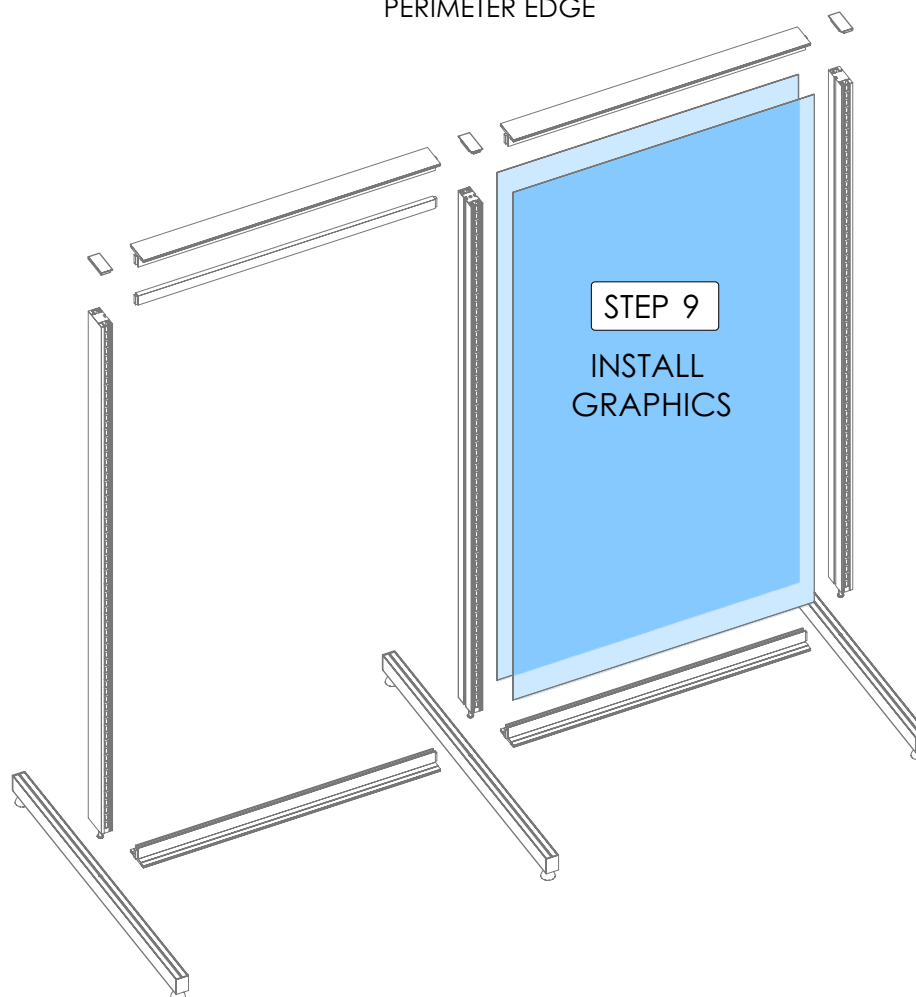
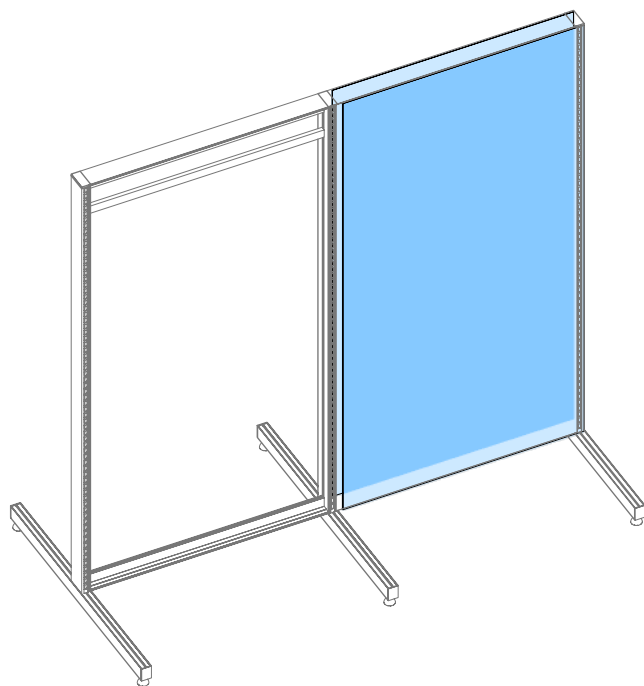

THEN PRESS ALONG THE PERIMETER EDGE



QTY	IMAGE	DESCRIPTION
4		36in WIDE X 17.25in DEEP - DROP-IN BASE PAN
6		36\"W X 12\"D SHELF

# SETUP INSTRUCTIONS

PLACE BASE PAN  
IN GROOVE(FOOT)

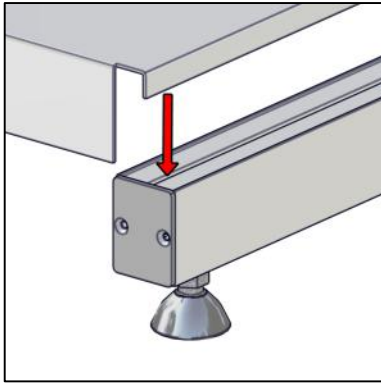

MFY-36-17-BASE-PAN

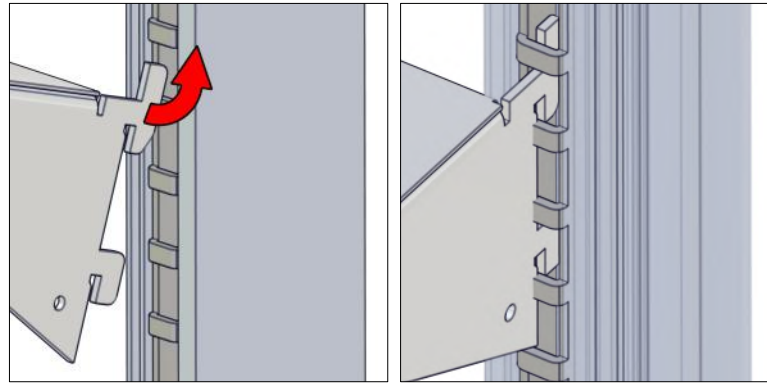

RAISE AND HOOK SHELF INTO PLACE  
\*\*START WITH BOTTOM SHELVES.

STEP 11

INSTALL SHELVES

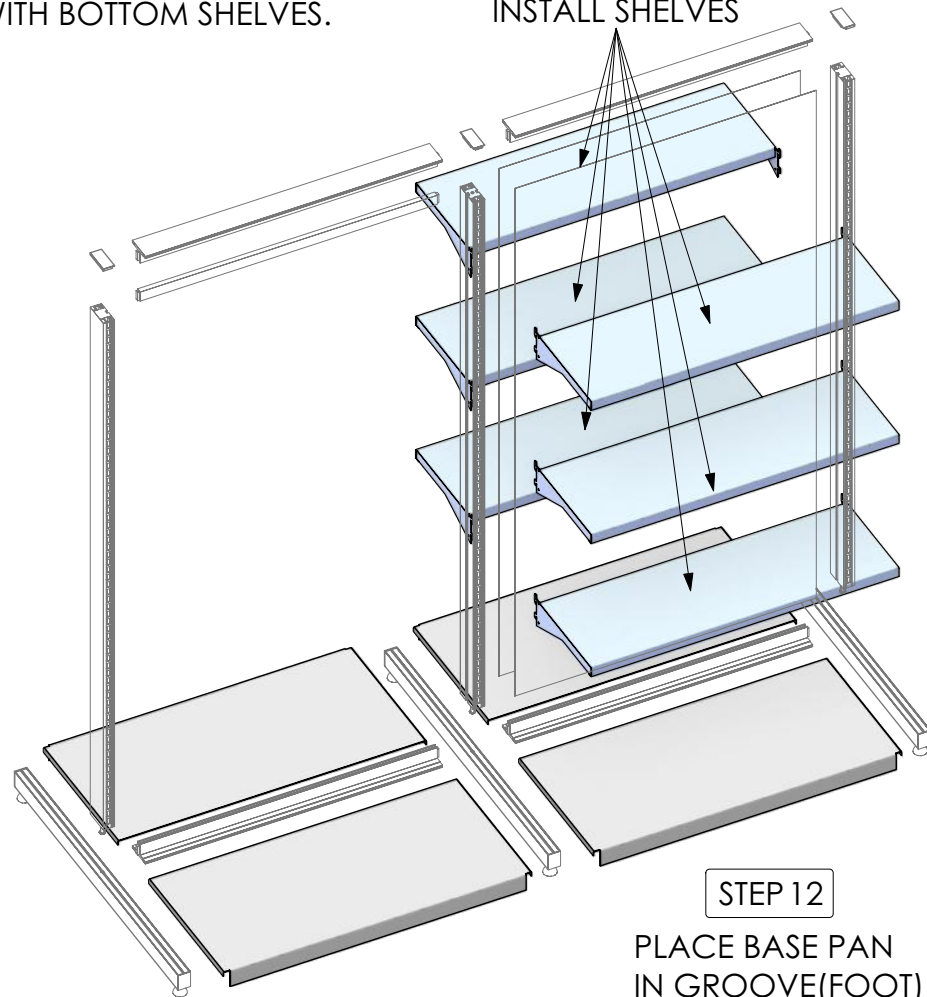

STEP 12

PLACE BASE PAN  
IN GROOVE(FOOT)

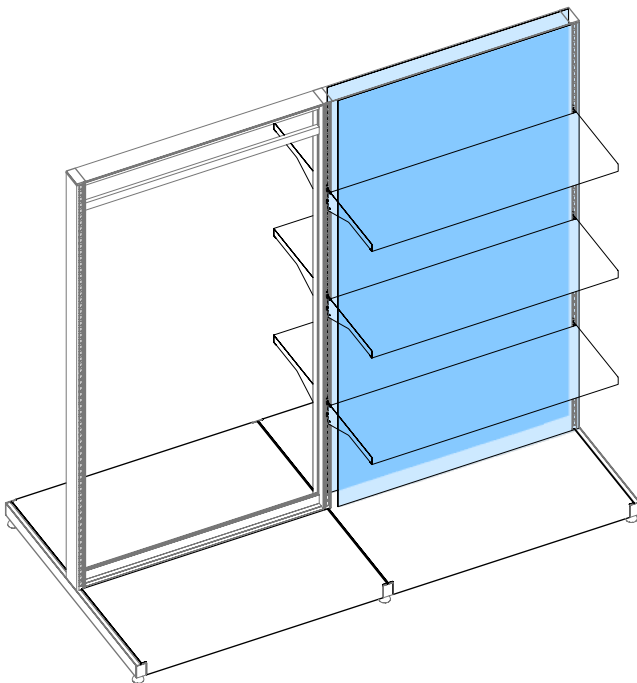





# Kit Hardware BOM

ITEM	COMPONENTS	QTY	DESCRIPTION
	101-883-01-01	1	883MM LENGTH OF PH1 EXTRUSION-WITH CAM LOCKS BOTH ENDS
	824-947	1	947MM (37.28IN) LEFT SUPPORT LEG
	824-947	1	947MM (37.28IN) MIDDLE SUPPORT LEG
	824-947	1	947MM (37.28IN) RIGHT SUPPORT LEG
	832-1740	1	1740MM (68.50in) MIDDLE UPRIGHT
	832-EC	1	7MM SEG PLASTIC END CAP FOR 832 EXTRUSION
	833-1740	1	1740MM (68.50in) LEFT UPRIGHT
	833-1740	1	1740MM (68.50in) RIGHT UPRIGHT
	833-EC	2	7MM SEG PLASTIC END CAP FOR 833 EXTRUSION
	835-883-01-01	4	883MM (34.76in) OF SINGLE SIDED SEG EXTRUSION -WITH CAM LOCKS BOTH ENDS
	MFY-BOLT-375-16-2.5	3	3/8-16 x 2.5"L bolt
	MFY-DB-36-17	4	36in WIDE X 17.25in DEEP - DROP-IN BASE PAN
	MFY-SLF-36-12	6	36"W X 12"D SHELF

# Kit Graphics BOM

	MFY-DS-03-A-G	1	(39.26 w X 72.60 h total size ) 35.26 w X 68.60 h finish size, Dye-sub print on Eclipse Blockout Stretch, single sided, sewn with FCE-2 silicone beading around perimeter & pull tab in bottom right corner (WITH 1/4" NOTCH LEFT & RIGHT BOTTOM HORIZONTAL SIDE CORNERS)
	MFY-DS-03-B-G	1	(39.26 w X 72.60 h total size ) 35.26 w X 68.60 h finish size, Dye-sub print on Eclipse Blockout Stretch, single sided, sewn with FCE-2 silicone beading around perimeter & pull tab in bottom right corner (WITH 1/4" NOTCH LEFT & RIGHT BOTTOM HORIZONTAL SIDE CORNERS)