

# MODify Single Sided Kit 02

MODify™ is a one-of-a-kind Retail Merchandising System that incorporates SEG push-fit fabric graphics that enable you to brand, promote and merchandise with ease. The MODify system is made up of interchangeable fixtures and accessories that can be easily assembled and rearranged to create a variety of different display configurations.

MODify Single Sided Kit 02 features a versatile slatwall for displaying merchandise simply and easily. With its push-fit fabric graphic header, branding changes and promotions can be effortlessly implemented, making this display an ideal choice for retailers seeking a versatile marketing solution. Easily configure with casters, towel bars, U bars, faceout bars, slatwall hooks, waterfalls, shelves and more.



MODify Single Sided Kits should be mounted to a wall or structure for safety and stability.

We are continually improving and modifying our product range and reserve the right to vary the specifications without prior notice. All dimensions and weights quoted are approximate and we accept no responsibility for variance. E&OE. See Graphic Templates for graphic bleed specifications

## features and benefits:

Base Kit includes:

- Frame, slatwall, shelf and base colors in kit are all the same, your choice of all white, black, or silver
- Heavy-duty aluminum frame, steel base
- Steel, slotted uprights
- 35"W x 72"H slatwall
- 35"W x 11"H SEG push-fit graphic header
- Drop-in base
- Display is easy to assemble and install
- Lifetime hardware warranty against manufacturer defects

Optional Accessories Include:

- Casters.
- U bars
- Slatwall hooks
- Shelves
- Towel bars
- Faceout bars
- Waterfalls

## dimensions:

### Hardware

Assembled unit:

37.5"W x 72"H x 20.5"D  
952.5mm(w) x 1828.8mm(h) x 520.7mm(d)

Approximate Weight:  
81 lbs / 36.741 kg

### Shipping

Packing case(s):  
1 Box

Shipping dimensions:  
(72"L x 14"H x 24"D)  
1828.8mm(l) x 355.6mm(h) x 609.6mm(d)

Approximate shipping weight:  
132 lbs / 59.8742 kg

## additional information:

### Graphics

Graphic material: Dye-sublimated fabric

See graphic templates for graphic sizes.

Refer to related graphic templates for more information Visit:

<https://www.theexhibitorshandbook.com/downloads/download-graphic-templates>  
or click here

Powder coat color options:



Wood laminate color options:



# MODify Accessories

All Accessories available in white, black, or silver

## Slotwall Accessories



MFY-SLT-HK  
4", 6", 8", 10" & 12"



MFY-SLT-FC  
6", 8", 10" & 12"

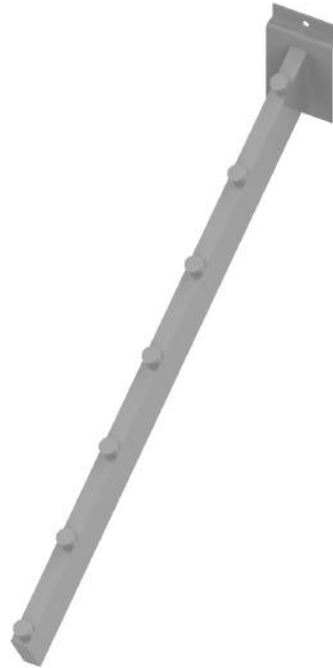

MFY-SLT-WTR-16-7

## U-Bar Accessories



MFY-TWL-FC  
6", 8" & 10"



MFY-UBR-FC  
6", 8" & 10"

MFY-CSTR-4-PK

## Shelf and Hanger Bars

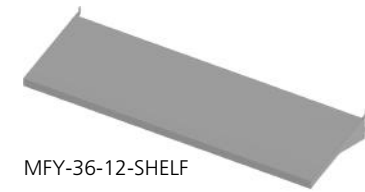

MFY-36-12-SHELF

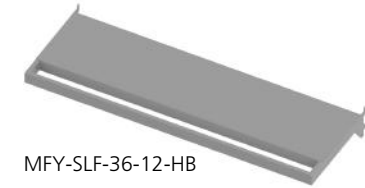

MFY-SLF-36-12-HB

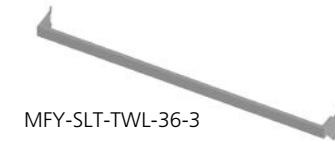

MFY-SLT-TWL-36-3

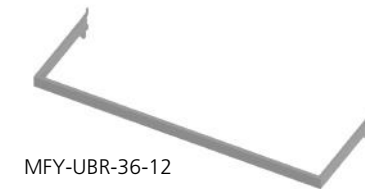

MFY-UBR-36-12

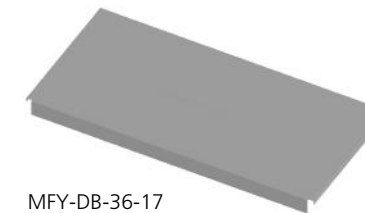

MFY-DB-36-17

# Tools Required



MULTI HEX KEY  
(INCLUDED)



PHILLIPS SCREW DRIVER  
(NOT INCLUDED)



9/16" SOCKET WRENCH  
(NOT INCLUDED)

## How to Apply & Remove Graphics

Installation and removal of SEG graphics is easy!

**Installation:** Push the SEG bead into each corner of the frame (1-4) with your thumb, then push the SEG bead into the middle of the run (5-8) and work your way around the perimeter of the frame until all beading is pushed in properly; if necessary, go around the perimeter again to ensure beading is secure in the extrusion profile.

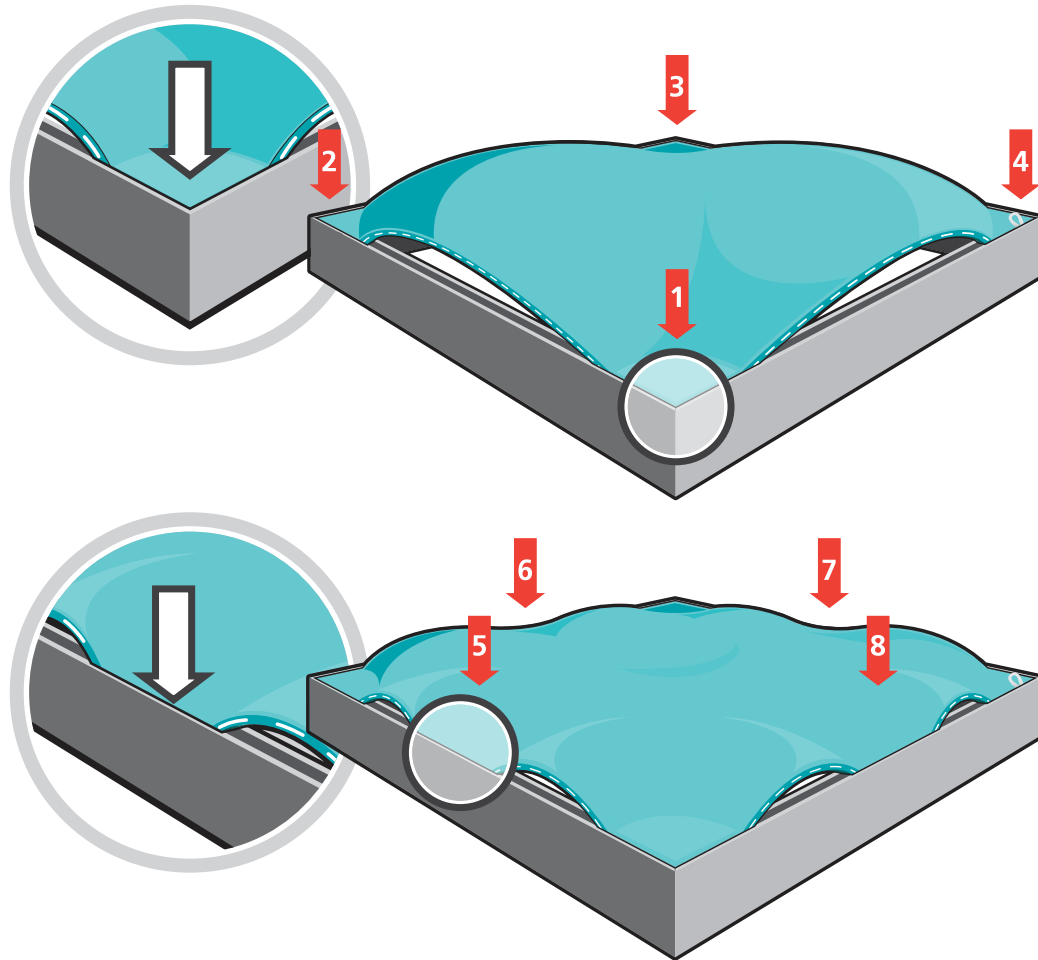



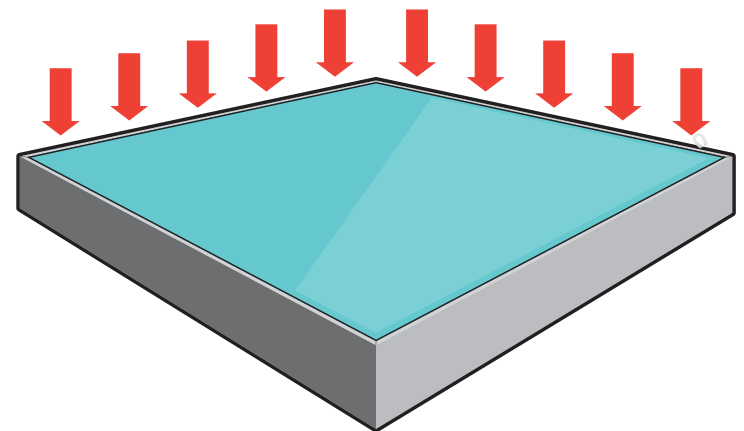

**Note:** Keep the set up area clean by using a drop cloth, washing hands before set-up or by wearing gloves.

**Removal:** Use the pull tab located on the graphic and gently pull the graphic from the frame, going around the perimeter.



## Graphics Storage & Care

Graphics should be folded with the graphic facing inward and stored in a zip lock /sealable plastic bag. Spot clean by wiping with a damp white cloth. If washing is necessary, use a commercial size front-loading washing machine, gentle cycle with cool water. Line dry flat. Dry cleaning is NOT recommended to prevent shrinkage.

QTY	IMAGE	DESCRIPTION
2		3/8-16 x 2.5" L bolt
1		1740MM (68.50in) LEFT UPRIGHT
1		1740MM (68.50in) RIGHT UPRIGHT
1		512MM (20.16IN) RIGHT SUPPORT LEG
1		512MM (20.16IN) LEFT SUPPORT LEG

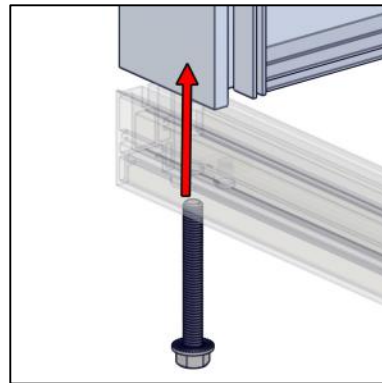
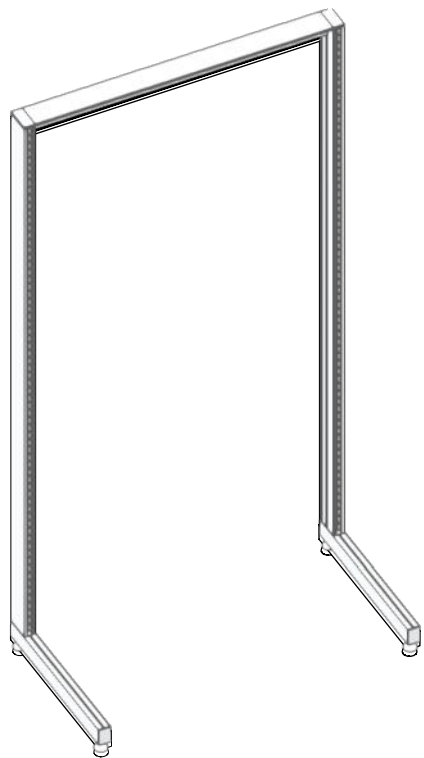

MFY-BOLT-375-16-2.5

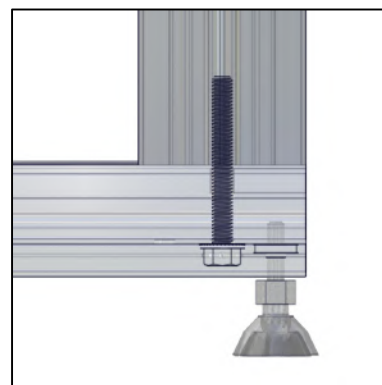

### SETUP INSTRUCTIONS

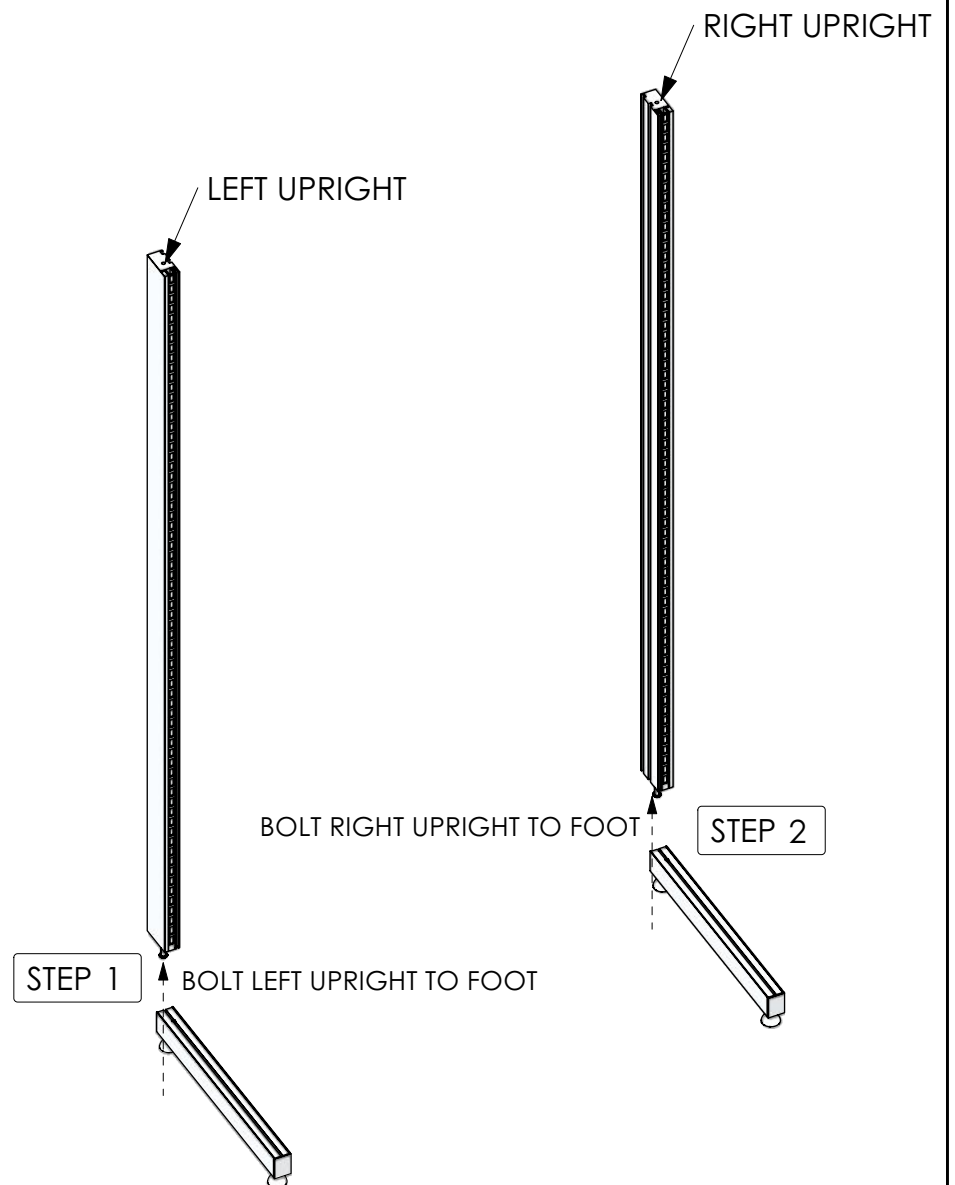

QTY	IMAGE	DESCRIPTION
1		883MM (34.7in) OF SWC EXTRUSION
2		1363MM (53.6in) OF SWC EXTRUSION
1		883MM (34.7in) OF SINGLE SIDED SEG EXTRUSION -WITH CAM LOCKS BOTH ENDS
2		WALL BRACKET

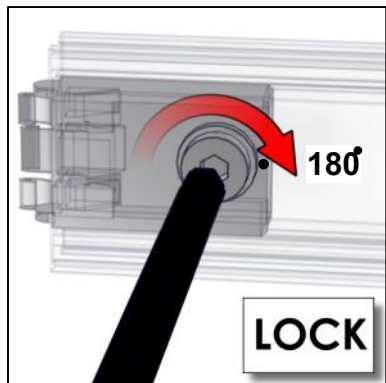

IMPORTANT! MAKE A HALF TURN TO LOCK EXTRUSIONS

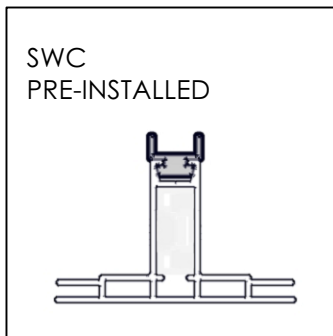
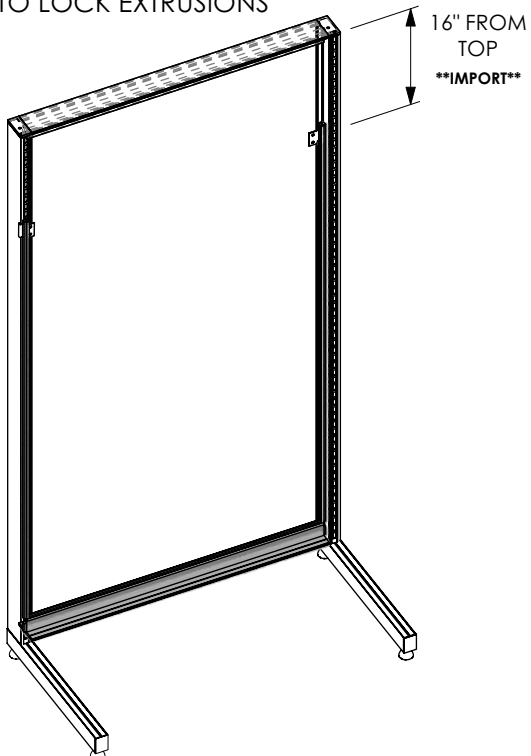

SLOTWALL TOP CHANNEL

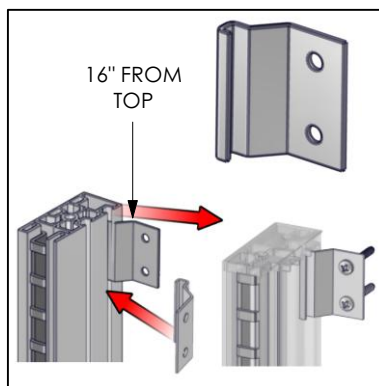

WALL MOUNT CLIPS

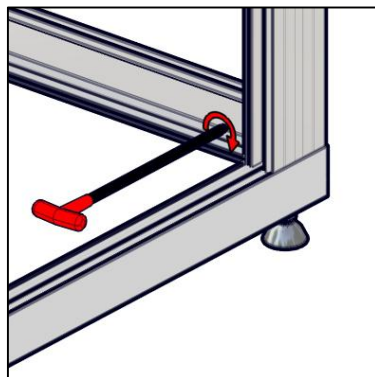

CROSS BRACE SITS ON SUPPORT LEG

## SETUP INSTRUCTIONS

STEP 4

\* LOCK TOP CROSS BRACE AND PLACE END CAPS TO ALIGN WALL BRACKETS (TEMPORARY)

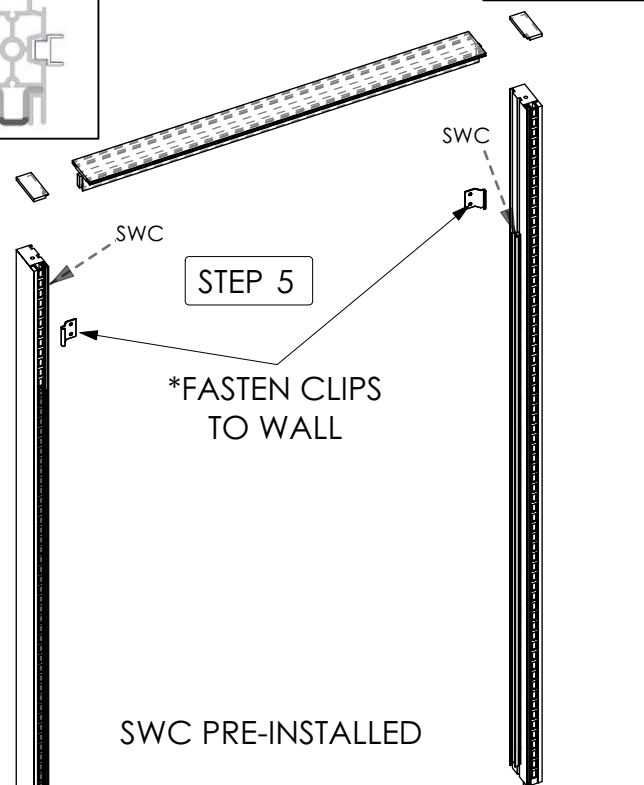
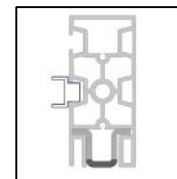
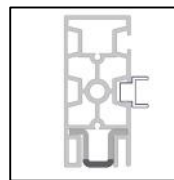

STEP 5

SWC PRE-INSTALLED

STEP 3

LOCK CROSS BRACE TO UPRIGHTS

NOTE: BOTTOM CROSS BRACE SITS ON TOP INSIDE EDGE OF LEFT AND RIGHT SUPPORT LEG

Disclaimer: Unit must be permanently secured and fastened to wall or other structure for stability.

QTY	IMAGE	DESCRIPTION
9		879MM (34.61in) LENGTH OF SLOTWALL EXTRUSION

\* REMOVE TOP CROSS BRACE AND PLACE END CAPS

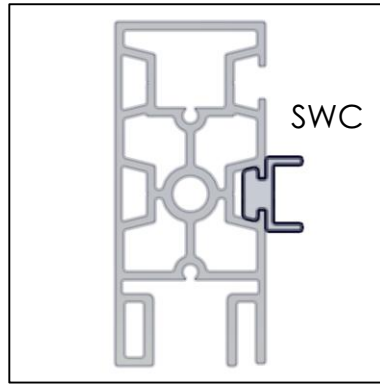

SLOTWALL CHANNEL

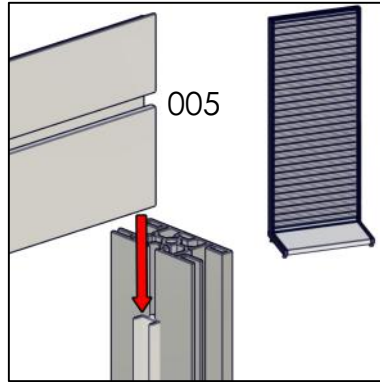

SLOTWALL EXTRUSION

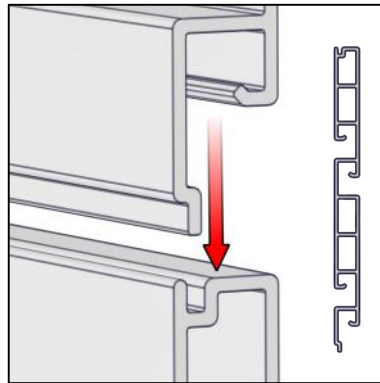



SETUP INSTRUCTIONS

STEP 5

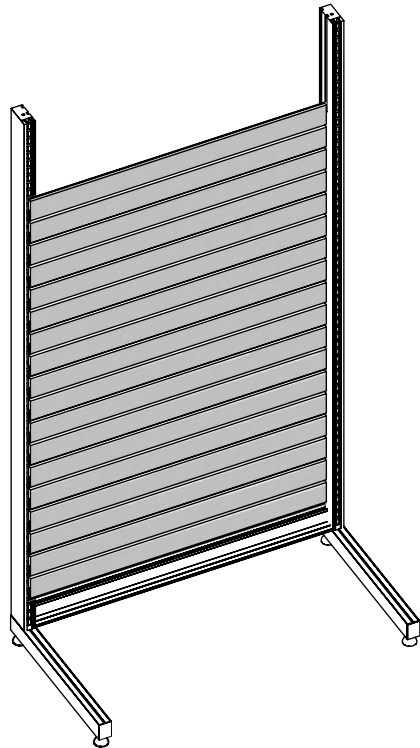
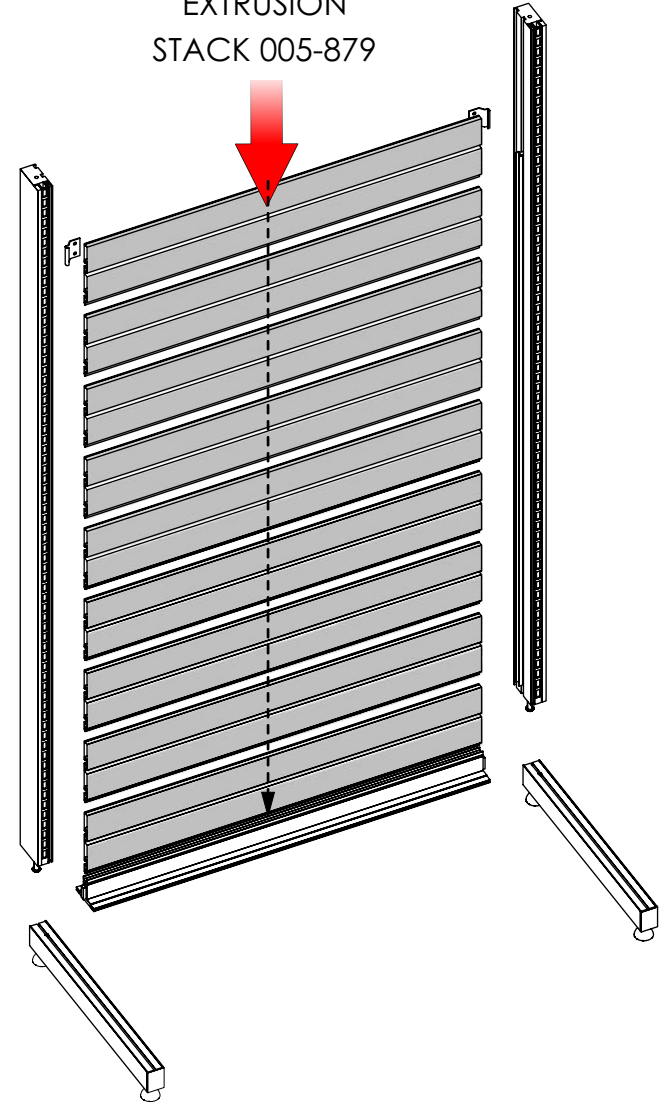
SLOTWALL EXTRUSION STACK 005-879





1		883MM (34.76in) OF SWC EXTRUSION
2		883MM (34.76in) OF SINGLE SIDED SEG EXTRUSION -WITH CAM LOCKS BOTH ENDS
2		7MM SEG PLASTIC END CAP FOR 831 EXTRUSION

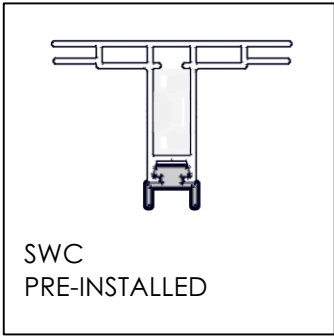

SLOTWALL BOTTOM CHANNEL

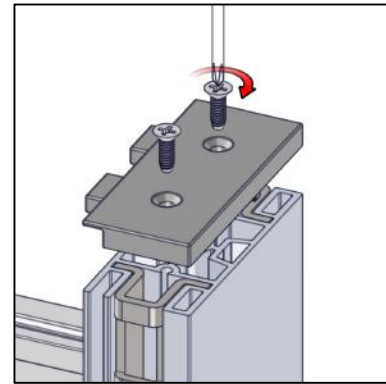
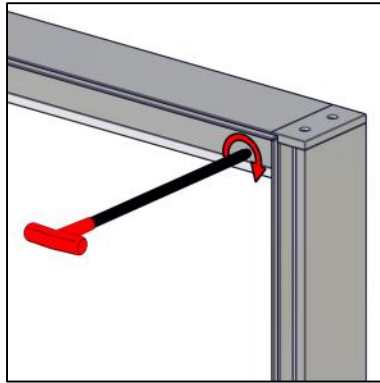
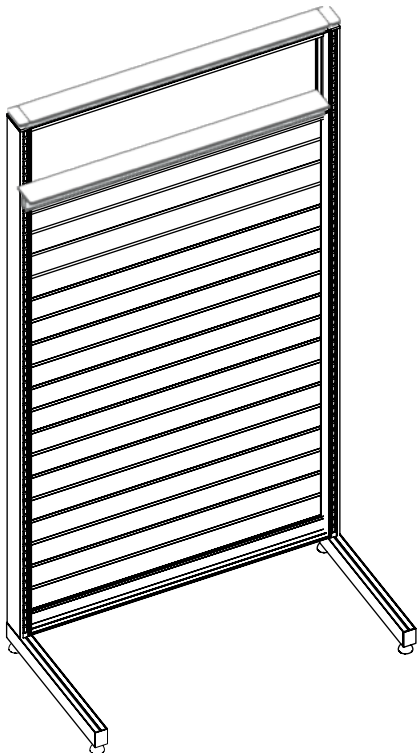

LOOSEN END CAP TO ATTACH TOP CROSS BRACE

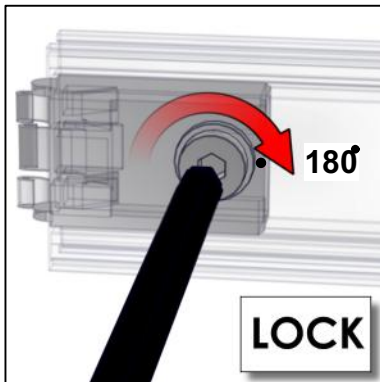

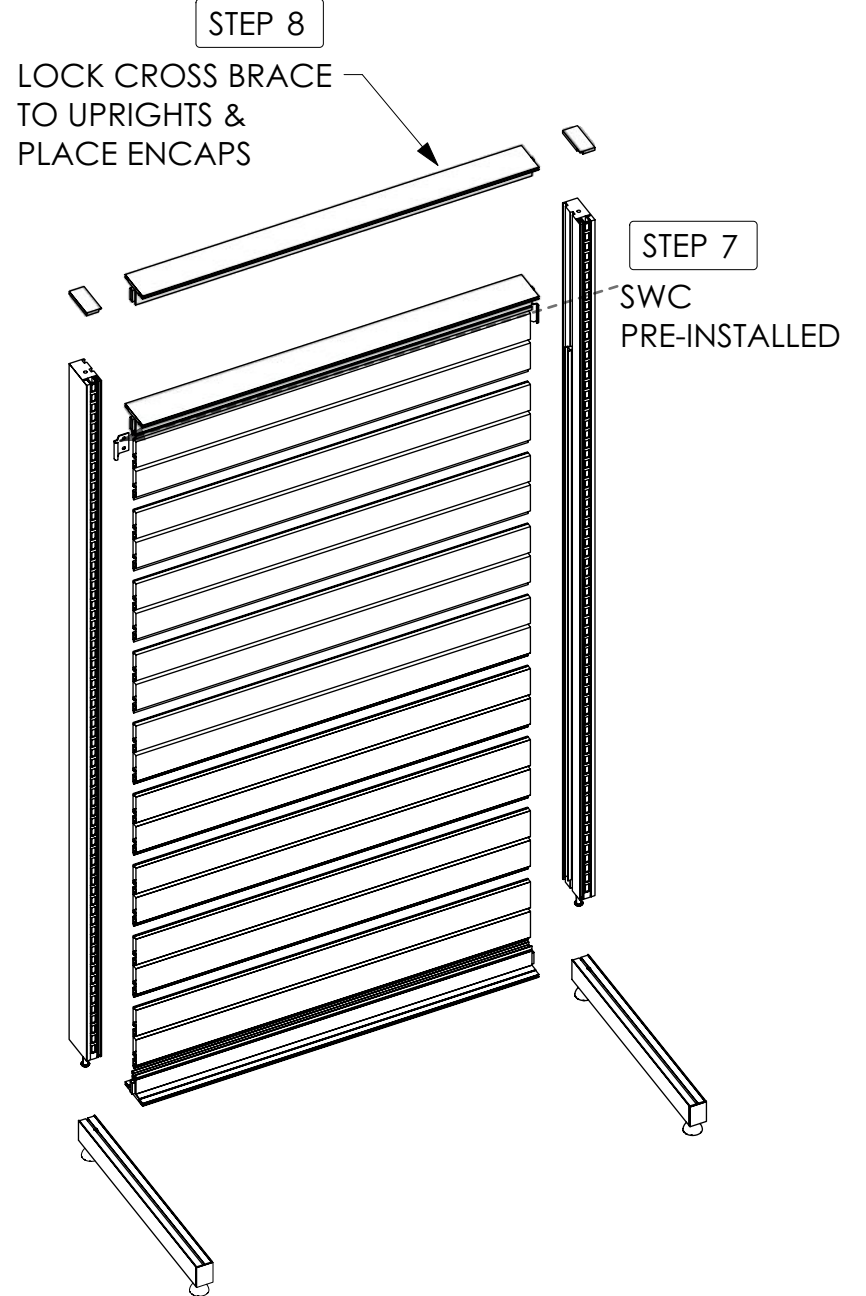

IMPORTANT!  
MAKE A HALF TURN  
TO LOCK EXTRUSIONS

SETUP INSTRUCTIONS





QTY	IMAGE	DESCRIPTION
1		36in WIDE X 17.25in DEEP - DROP-IN BASE PAN
1		(39.26 w X 15.06 h total size ) 35.26 w X 11.06 h finish size, Dye-sub print on Eclipse Blockout Stretch, single sided, sewn with FCE-2 silicone beading around perimeter & pull tab in bottom right corner (WITH 1/4" NOTCH LEFT & RIGHT BOTTOM HORIZONTAL SIDE CORNERS)

# SETUP INSTRUCTIONS

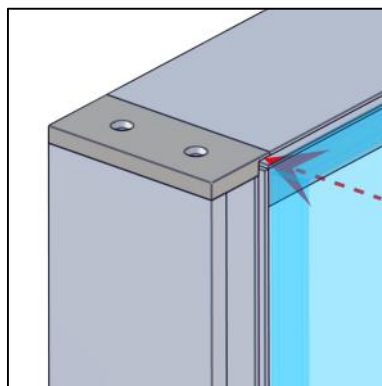

PRESS GRAPHIC INTO CORNERS

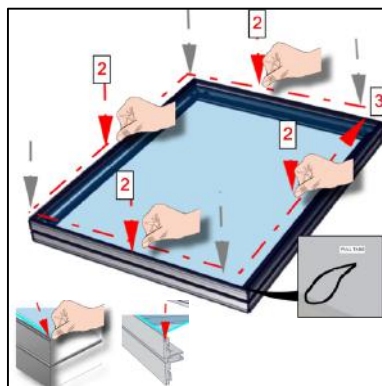

THEN PRESS ALONG THE PERIMETER EDGE

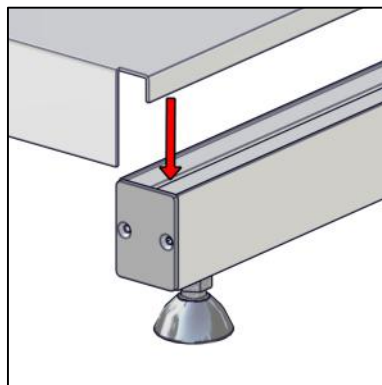

MFY-36-17-BASE-PAN

## STEP 9

### INSTALL GRAPHICS

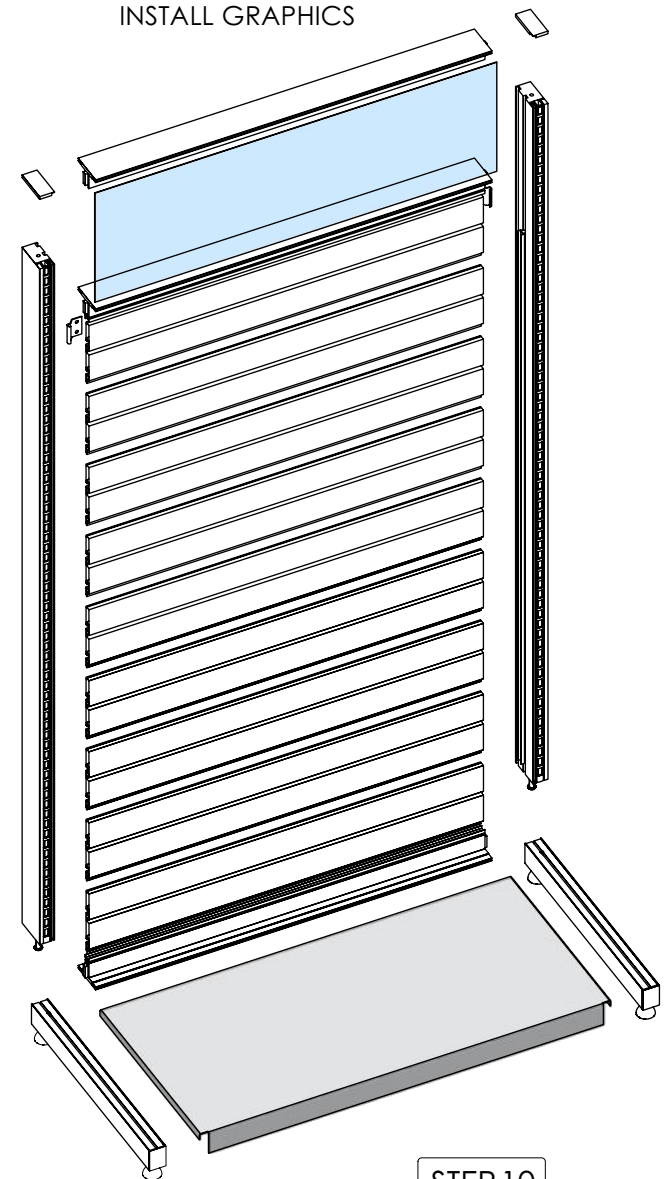





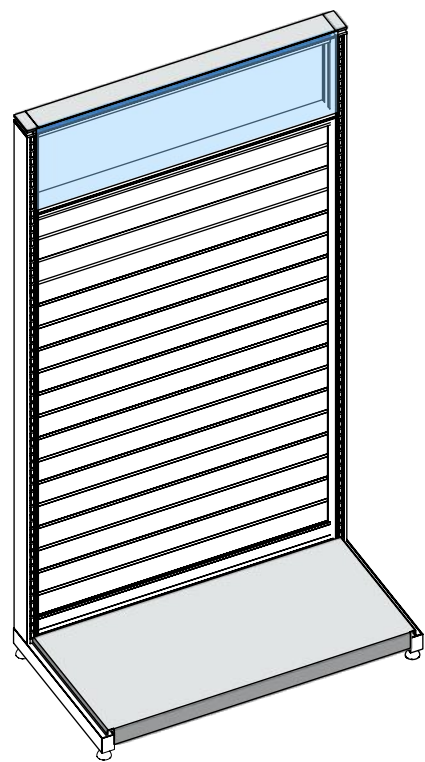





## STEP 10

### INSTALL BASE PAN



# Kit Hardware BOM

ITEM	COMPONENTS	QTY	DESCRIPTION
	004-883	2	883MM (34.76in) OF SWC EXTRUSION
	004-1363	2	1363MM (53.66in) OF SWC EXTRUSION
	005-879	9	879MM (34.61in) LENGTH OF SLOTWALL EXTRUSION
	824-512	1	512MM (20.16in) LEFT SUPPORT LEG
	824-512	1	512MM (20.16in) RIGHT SUPPORT LEG
	831-1740	1	1740MM (68.50in) LEFT UPRIGHT
	831-1740	1	1740MM (68.50in) RIGHT UPRIGHT
	831-EC	2	7MM SEG PLASTIC END CAP FOR 831 EXTRUSION
	835-883-01-01	3	883MM (34.76in) OF SINGLE SIDED SEG EXTRUSION -WITH CAM LOCKS BOTH ENDS
	MFY-BOLT-375-16-2.5	2	3/8-16 x 2.5"L bolt
	MFY-BRKT3	2	WALL BRACKET
	MFY-DB-36-17	1	36in WIDE X 17.25in DEEP - DROP-IN BASE PAN

# Kit Graphics BOM

ITEM	COMPONENTS	QTY	DESCRIPTION
	MFY-SS-02-G	1	(39.26 w X 15.06 h total size ) 35.26 w X 11.06 h finish size, Dye-sub print on Eclipse Blockout Stretch, single sided, sewn with FCE-2 silicone beading around perimeter & pull tab in bottom right corner (WITH 1/4" NOTCH LEFT & RIGHT BOTTOM HORIZONTAL SIDE CORNERS)