

# MODify Gondola Kit 01

MODify™ is a one-of-a-kind Modular Merchandising System that is made up of interchangeable fixtures and accessories that can be easily assembled, disassembled, and rearranged to create a variety of different display configurations. The MODify system incorporates SEG push-fit fabric graphics that enable you to brand, promote and merchandise with ease.

MODify Gondola Kit 01 is a merchandising mecca that is versatile and durable. The easy-to-assemble base kit features eight push-fit graphic panels and a double-sided slatwall panel. This kit provides the flexibility to MODify with optional shelving, hooks, and other fixtures to create an attractive and functional retail display.



We are continually improving and modifying our product range and reserve the right to vary the specifications without prior notice. All dimensions and weights quoted are approximate and we accept no responsibility for variance. E&OE. See Graphic Templates for graphic bleed specifications

## features and benefits:

Base Kit includes:

- Frame, slatwall, shelf and base colors in kit are all the same, your choice of all white, black, or silver
- Heavy-duty aluminum frame, steel base
- Steel, slotted uprights
- Five frames: two ends, two center, one header
- 35"W x 57"H (full height) slatwall on front & back
- End caps each hold a 35"W x 57"H SEG push-fit fabric graphic, black liners on inside
- Two 35"W x 57"H push-fit fabric graphics on inside of display
- Frame topper with 59"W x 12"H SEG push-fit graphic, one on each side
- Non-rolling base
- Display is easy to assemble and install
- Lifetime hardware warranty against manufacturer defects

Optional Accessories Include:

- Towel bars.
- Faceout bars
- Waterfalls
- U bars
- Slatwall hooks
- Shelves

## dimensions:

### Hardware

Assembled unit:

76.5"W x 72"H x 37.5"D  
1943.1mm(w) x 1828.8mm(h) x 952.5mm(d)

Approximate Weight:  
202 lbs / 91.6257 kg

### Shipping

Packing case(s):  
1 Box

Shipping dimensions:  
(62" L x 24" H x 24" D)  
1574.8mm(l) x 609.6mm(h) x 609.6mm(d)

Approximate shipping weight:  
279 lbs / 126.552 kg

### Graphics

Graphic material: Dye-sublimated fabric

See graphic templates for graphic sizes.

Refer to related graphic templates for more information Visit:

<https://www.theexhibitorshandbook.com/downloads/download-graphic-templates>  
or click here

## additional information:

Powder coat color options:



Wood laminate color options:



# MODify Accessories

All Accessories available in white, black, or silver

## Slotwall Accessories



MFY-SLT-HK  
4", 6", 8", 10" & 12"



MFY-SLT-FC  
6", 8", 10" & 12"

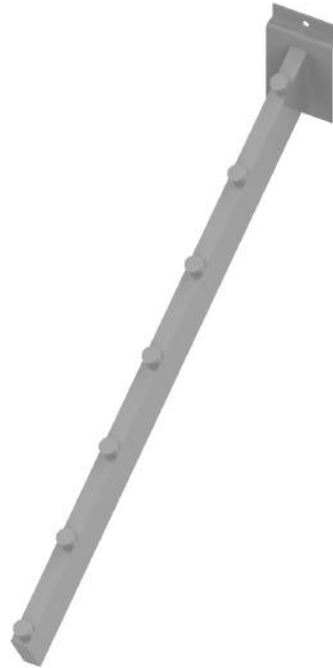

MFY-SLT-WTR-16-7

## U-Bar Accessories



MFY-TWL-FC  
6", 8" & 10"



MFY-UBR-FC  
6", 8" & 10"



MFY-CSTR-4-PK

## Shelf and Hanger Bars

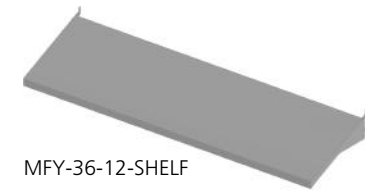

MFY-36-12-SHELF

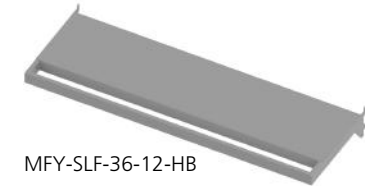

MFY-SLF-36-12-HB

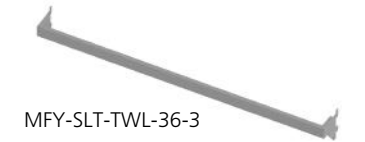

MFY-SLT-TWL-36-3

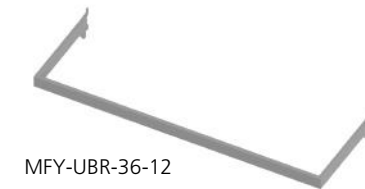

MFY-UBR-36-12

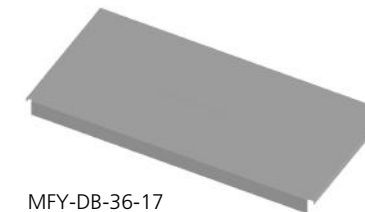

MFY-DB-36-17

# Tools Required



MULTI HEX KEY  
(INCLUDED)



PHILLIPS SCREW DRIVER  
(NOT INCLUDED)



9/16" SOCKET WRENCH  
(NOT INCLUDED)

## How to Apply & Remove Graphics

Installation and removal of SEG graphics is easy!

**Installation:** Push the SEG bead into each corner of the frame (1-4) with your thumb, then push the SEG bead into the middle of the run (5-8) and work your way around the perimeter of the frame until all beading is pushed in properly; if necessary, go around the perimeter again to ensure beading is secure in the extrusion profile.

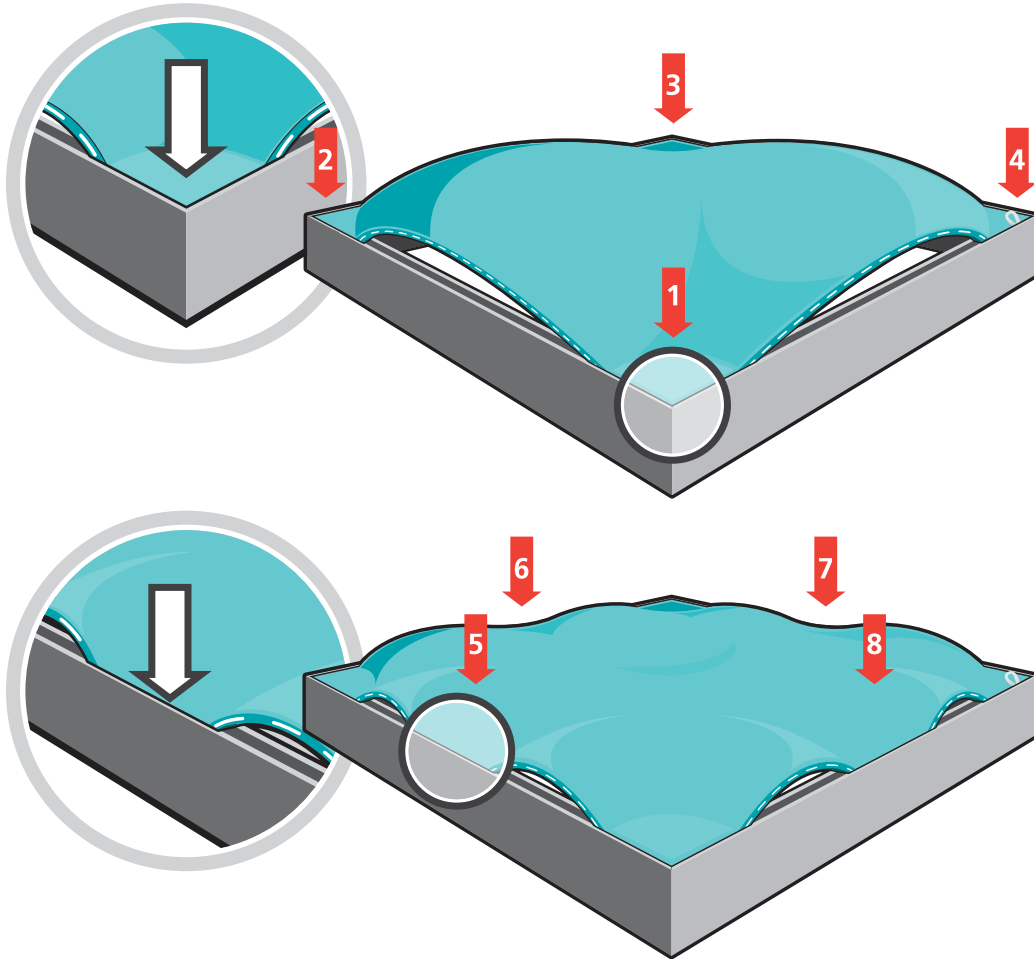

**Note:** Keep the set up area clean by using a drop cloth, washing hands before set-up or by wearing gloves.

**Removal:** Use the pull tab located on the graphic and gently pull the graphic from the frame, going around the perimeter.

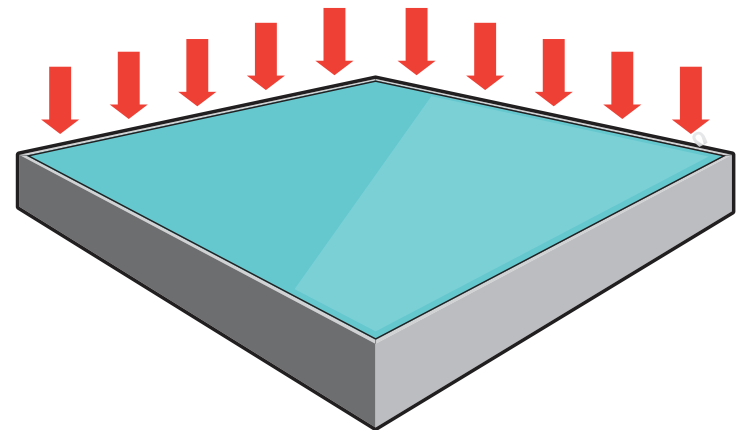

## Graphics Storage & Care

Graphics should be folded with the graphic facing inward and stored in a zip lock /sealable plastic bag. Spot clean by wiping with a damp white cloth. If washing is necessary, use a commercial size front-loading washing machine, gentle cycle with cool water. Line dry flat. Dry cleaning is NOT recommended to prevent shrinkage.

QTY	IMAGE	DESCRIPTION
3		3/8-16 x 2.5-3"L bolt
1		1435MM (56.50in) LEFT UPRIGHT
1		1435MM (56.50in) OF 832 DOUBLE SIDED UPRIGHT OPEN EXTRUSION
1		947MM (37.28IN) LEFT SUPPORT LEG
2		1335MM (52.56in) OF SWC EXTRUSION
1		947MM (37.28IN) LENGTH OF 824 CORNER POST EXTRUSION -WITH HOLE FOR 3/8 BOLT
1		1435MM (56.50in) OF 832 RIGHT UPRIGHT
1		947MM (37.28IN) RIGHT SUPPORT LEG

## SETUP INSTRUCTIONS

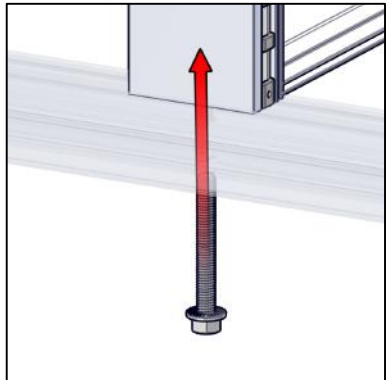

MFY-BOLT-375-16-2.5

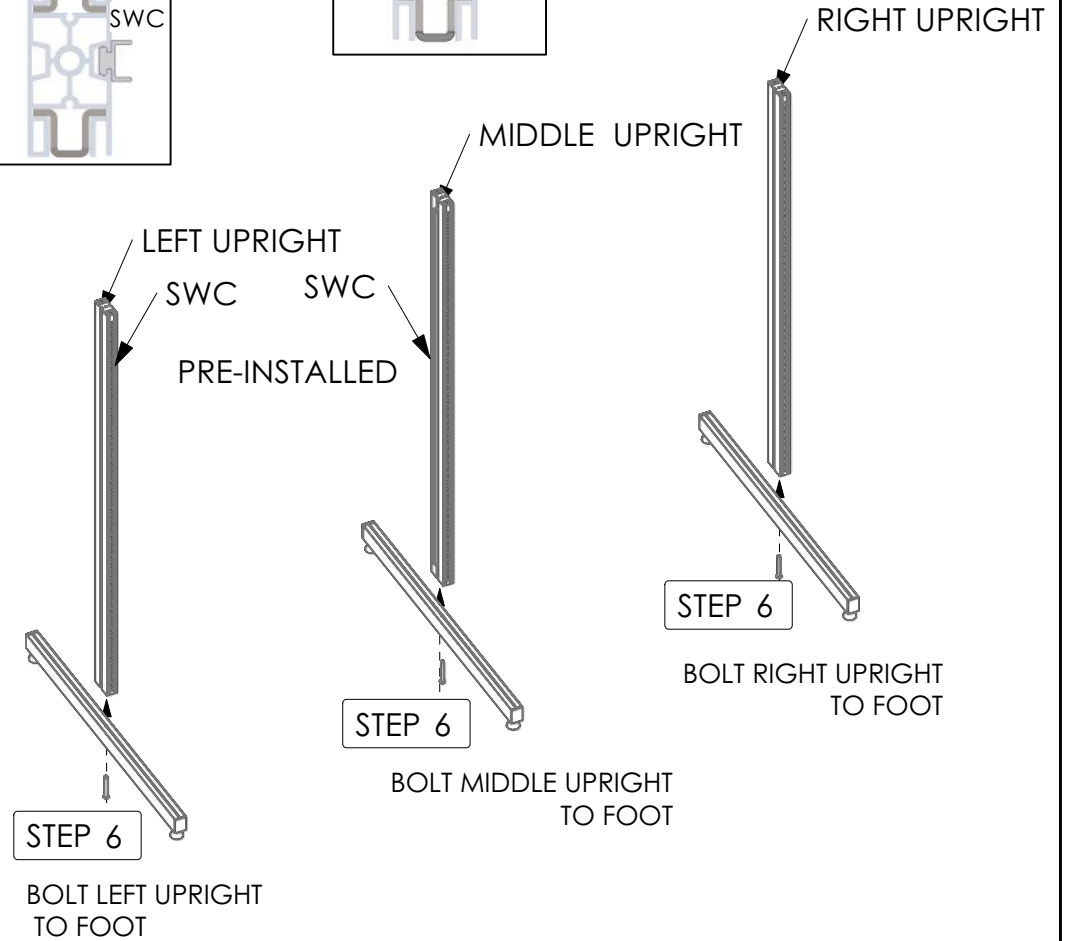
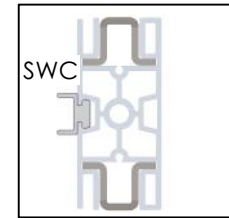
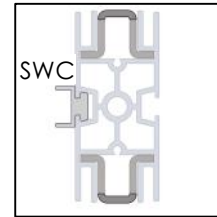
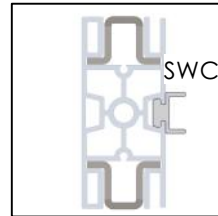
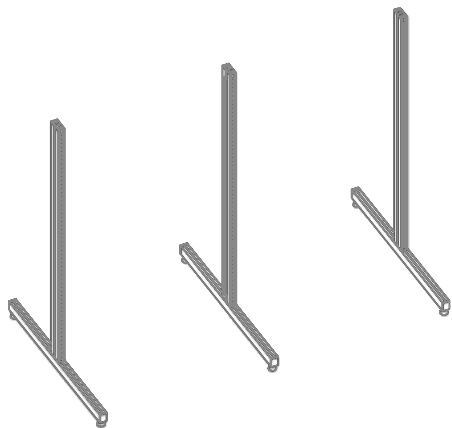
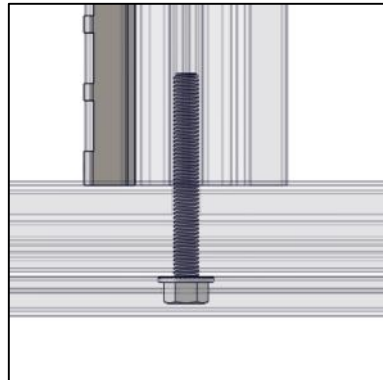

QTY	IMAGE	DESCRIPTION
8		879MM (34.61in) LENGTH OF SLOTWALL EXTRUSION
1		879MM (34.61in) LENGTH OF SLOTWALL EXTRUSION -WITH 30MM BOTTOM CUT
1		883MM (34.76in) OF SWC EXTRUSION
2		883MM (34.76in) OF SINGLE SIDED SEG EXTRUSION -WITH CAM LOCKS BOTH ENDS

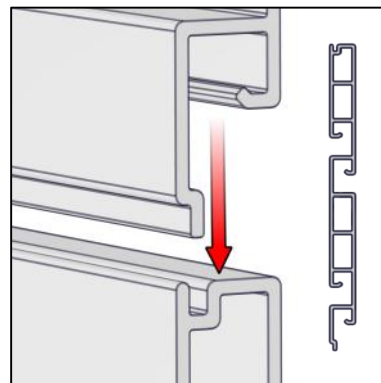
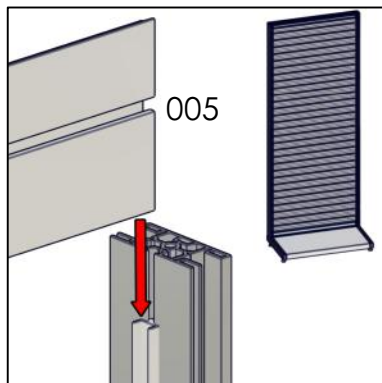

## SETUP INSTRUCTIONS

### SLOTWALL EXTRUSION

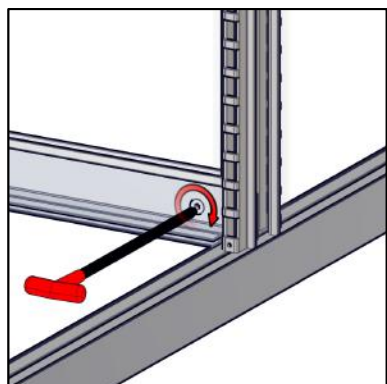

CROSS BRACE SITS ON SUPPORT LEGS

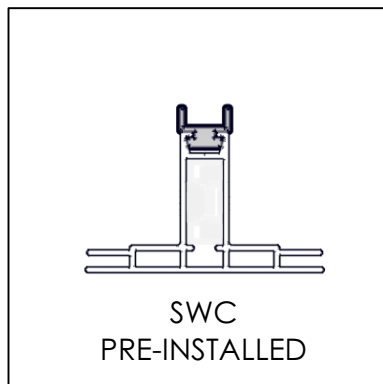

SLOT WALL TOP CHANNEL

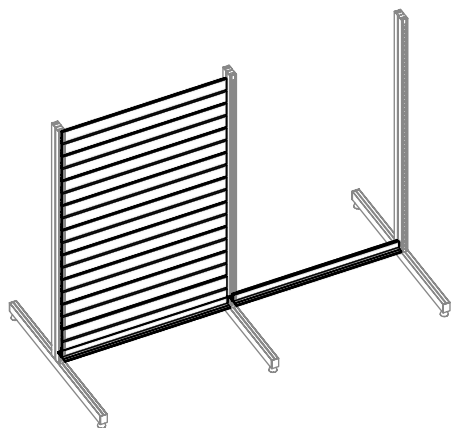

5" HEIGHT  
**\*INSTALL FIRST**  
BOTTOM CUT  
SLOTWALL

6.125" HEIGHT  
SLOTWALL

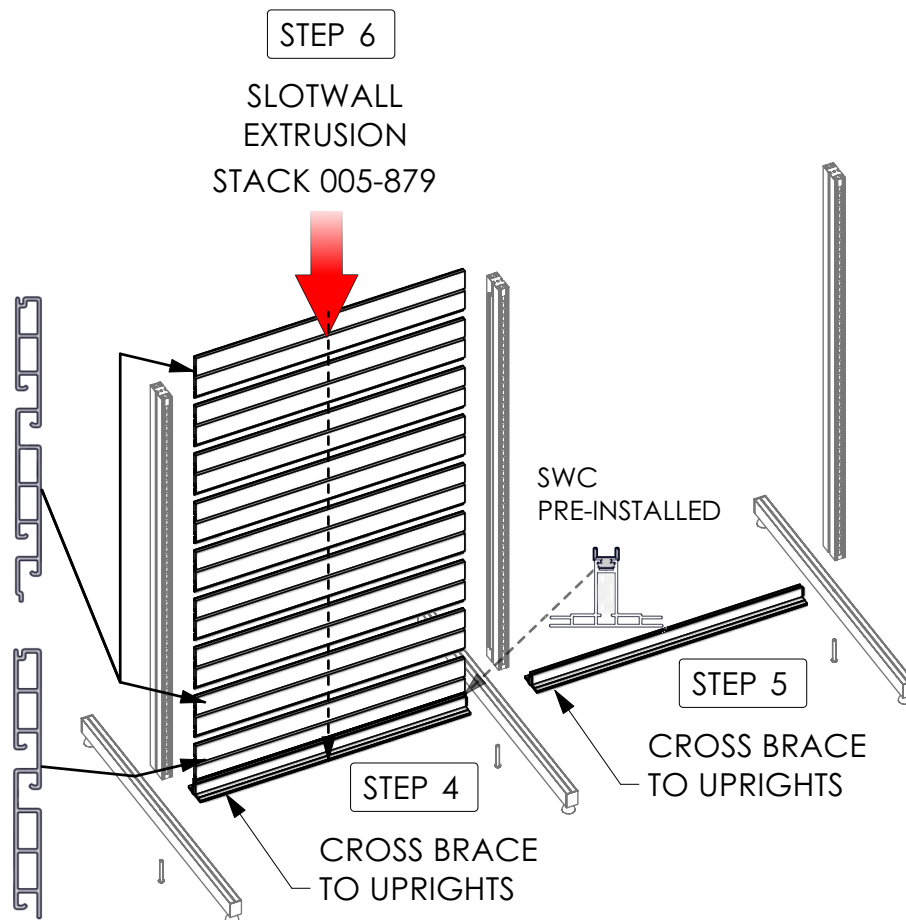

# SETUP INSTRUCTIONS

QTY	IMAGE	DESCRIPTION
2		883MM (34.7in) OF SINGLE SIDED SEG EXTRUSION -WITH CAM LOCKS BOTH ENDS
1		883MM (34.7in) OF SWC EXTRUSION
3		7MM SEG PLASTIC END CAP FOR 832 EXTRUSION

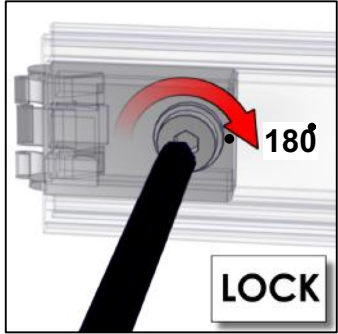

IMPORTANT!  
MAKE A HALF TURN  
TO LOCK EXTRUSIONS

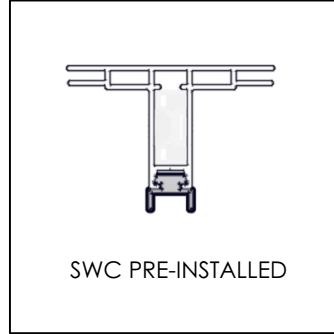
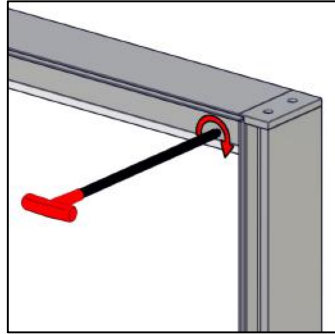

SWC PRE-INSTALLED

SLOT WALL BOTTOM  
CHANNEL

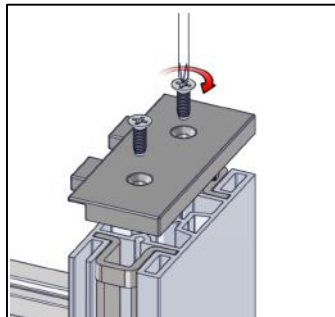

LOOSEN END CAP TO ATTACH  
TOP CROSS BRACE

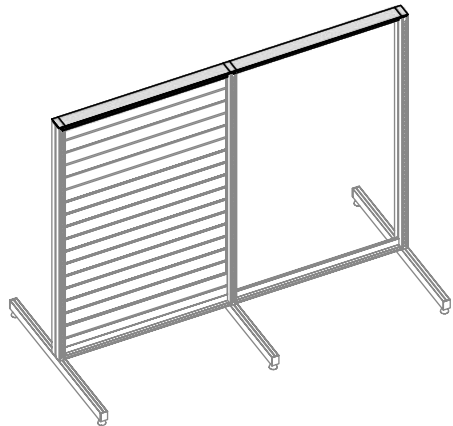

## STEP 7

LOCK CROSS BRACE  
TO UPRIGHTS AND PLACE END  
CAPS

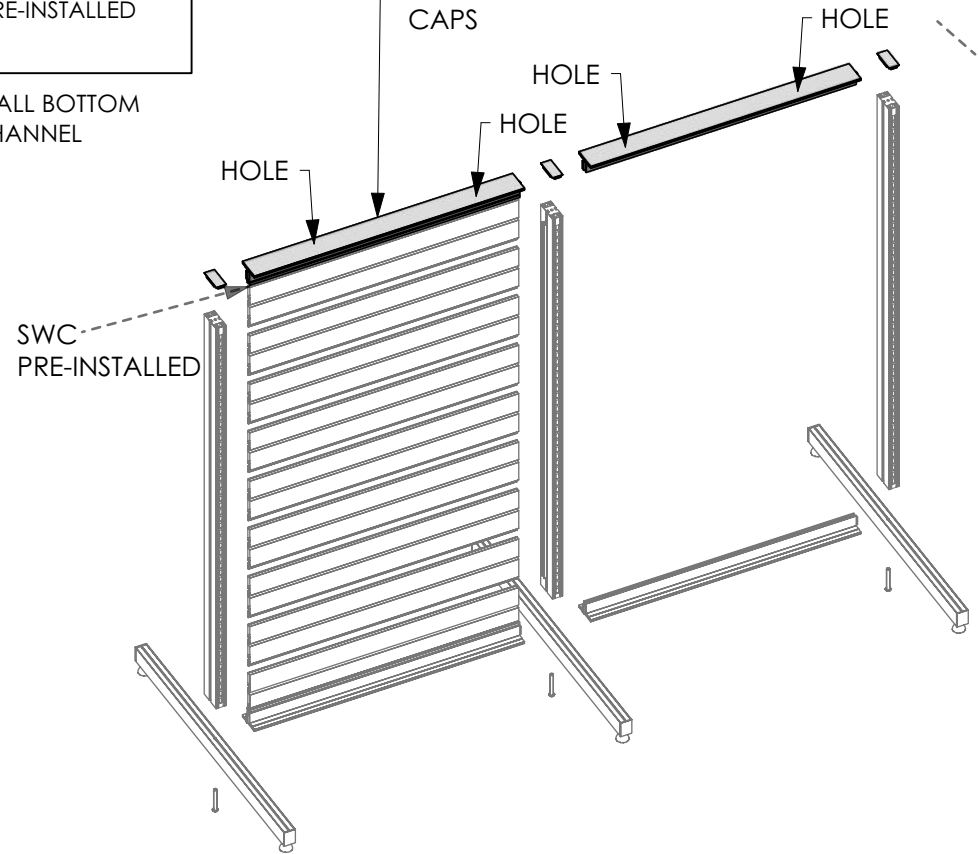



QTY	IMAGE	DESCRIPTION
2		1500MM (59.06in) LENGTH OF WMFCD EXTRUSION 45 DEGREE MITER CUT BOTH ENDS
4		SINGLE VECTOR CORNER CLEAT
2		305MM (12.01in) LENGTH OF WMFCD EXTRUSION 45 DEGREE MITER CUT BOTH ENDS
4		1/4"-20 x 1"L bolt

## SETUP INSTRUCTIONS

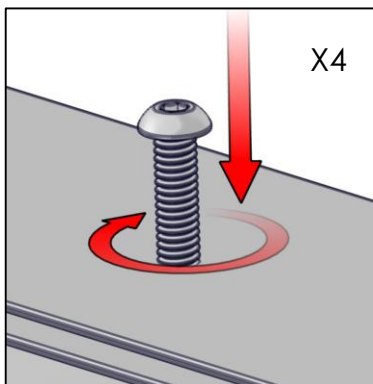

**STEP 9**  
BOLT TOP FRAME  
TO CROSS BRACE

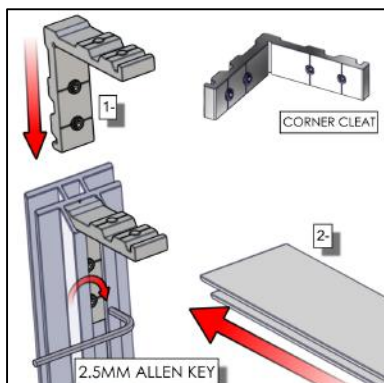

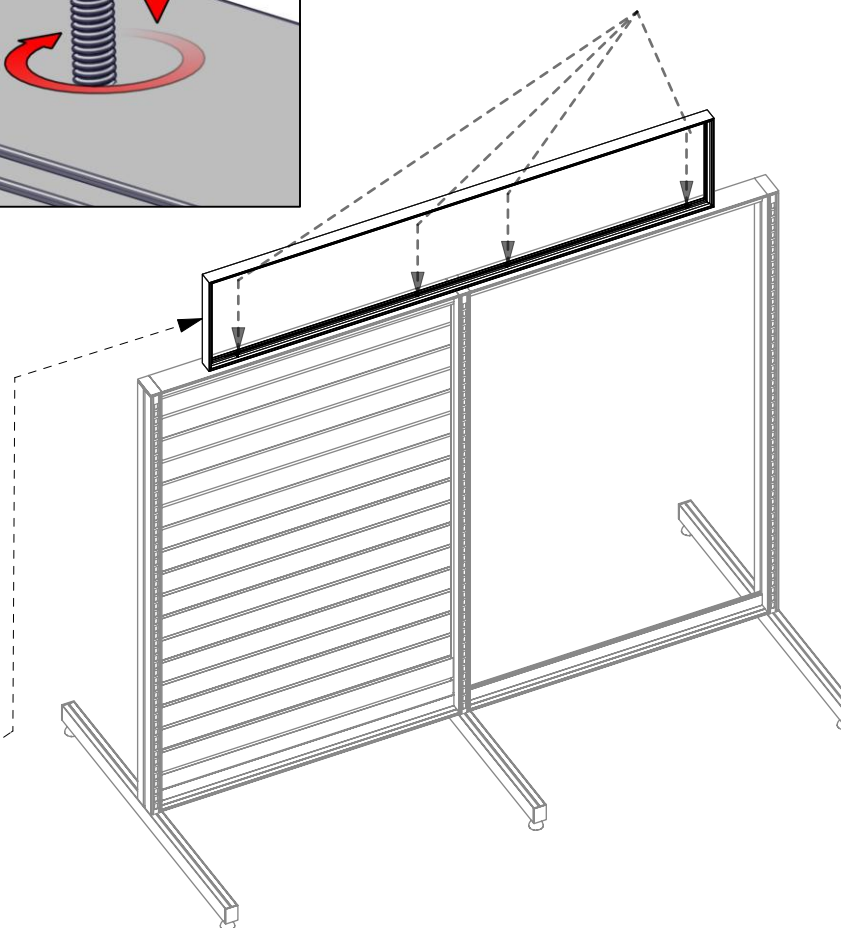
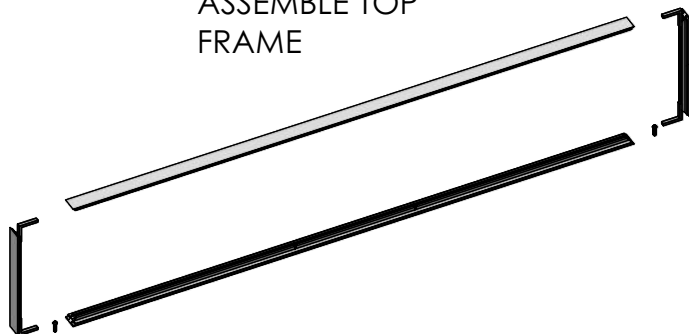

CORNER CLEAT

**STEP 8**  
ASSEMBLE TOP  
FRAME





# SETUP INSTRUCTIONS

QTY	IMAGE	DESCRIPTION
2		(62.94 w X 15.88 h total size ) 58.94 w X 11.88 h finish size, Dye-sub print on Eclipse Blockout Stretch, single sided, sewn with FCE-2 silicone beading around perimeter & pull tab in bottom right corner
2		(39.26 w X 60.59 h total size ) 35.26 w X 56.59 h finish size, Dye-sub print on Eclipse Blockout Stretch, single sided, sewn with FCE-2 silicone beading around perimeter & pull tab in bottom right corner (WITH 1/4" NOTCH LEFT & RIGHT BOTTOM HORIZONTAL SIDE CORNERS)

## STEP 10

### INSTALL GRAPHICS

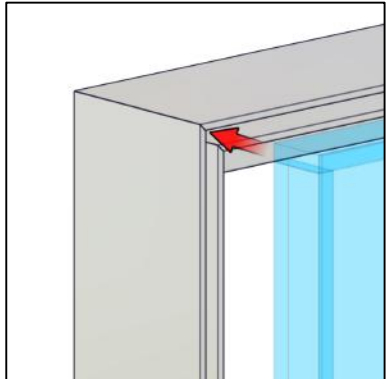
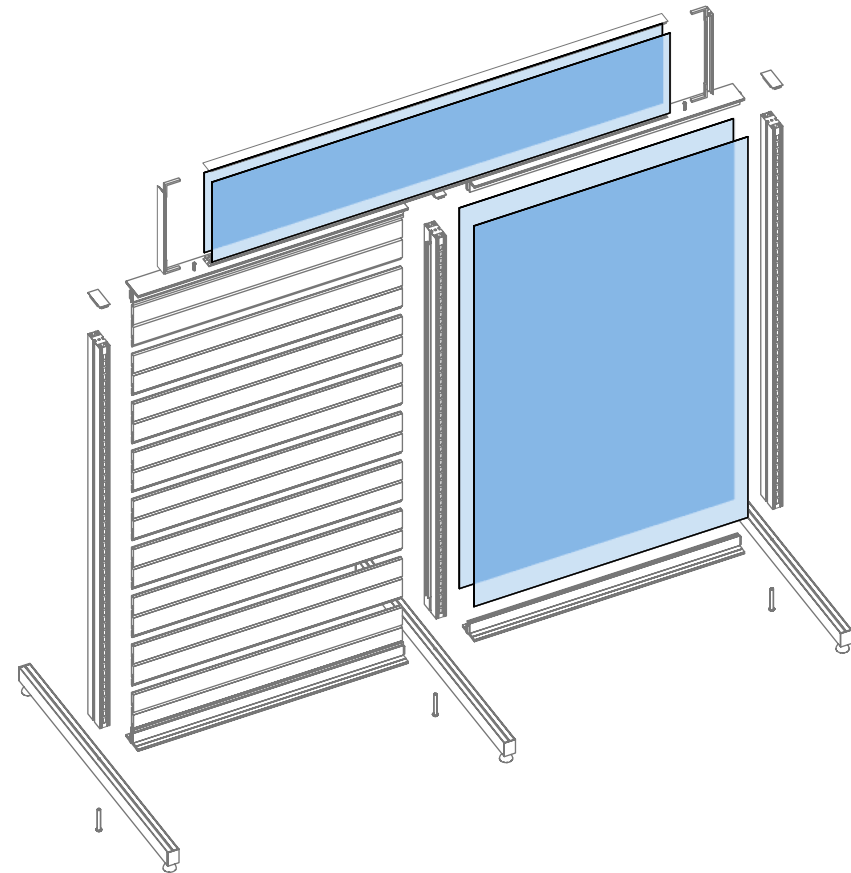



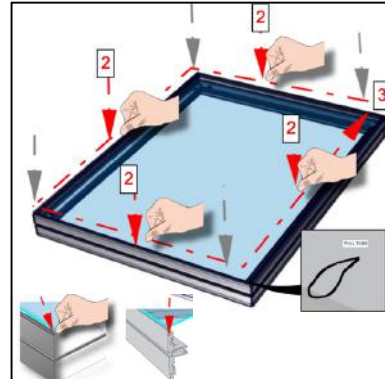



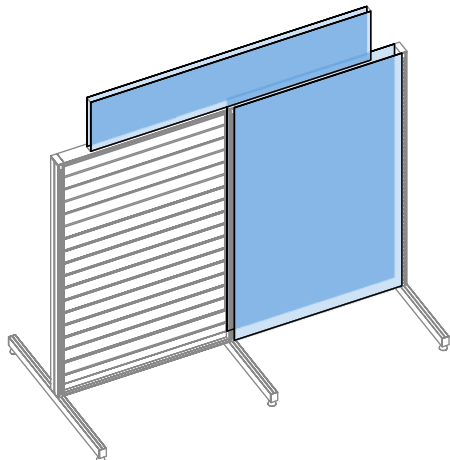

PRESS GRAPHIC INTO CORNERS



THEN PRESS ALONG THE PERIMETER EDGE



QTY	IMAGE	DESCRIPTION
2		1486MM (58.50in) RIGHT UPRIGHT
4		883MM (34.76in) OF SINGLE SIDED SEG EXTRUSION -WITH CAM LOCKS BOTH ENDS
2		1486MM (58.50in) LEFT UPRIGHT
1		1435MM (56.50in) LENGTH OF BLACK POWDERCOATED METAL SHELF STANDARD EXTRUSION
4		1338MM CUT DOWN FROM 1500MM LENGTH OF FC EXTRUSION
4		883MM CUT DOWN FROM 900MM LENGTH OF FC EXTRUSION-WITH ROUTES
4		7MM SEG PLASTIC END CAP FOR 821 EXTRUSION
4		2.0" END CAP STANDARD STOP, ALUMINUM

LEFT FRAME



RIGHT FRAME

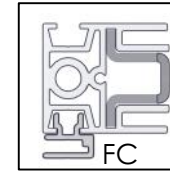

TOP VIEW

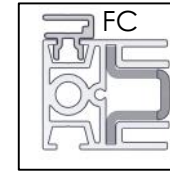
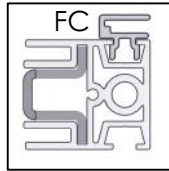

SETUP INSTRUCTIONS

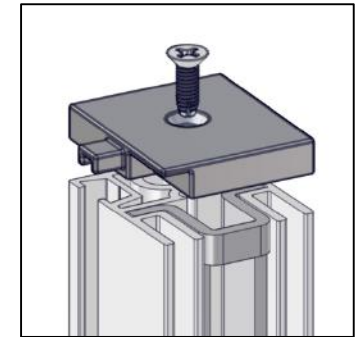
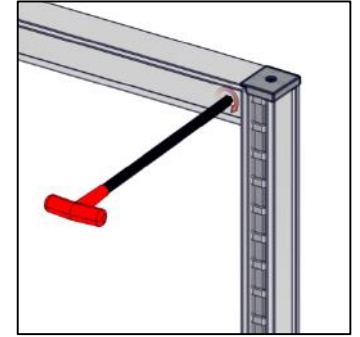

LOOSEN END CAP TO ATTACH TOP CROSS BRACE

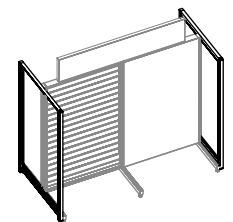

STEP 10

ASSEMBLE LEFT & RIGHT FRAMES

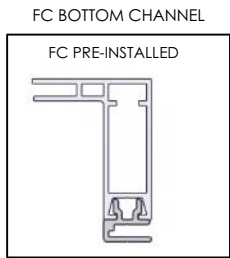

FC BOTTOM CHANNEL

FC PRE-INSTALLED

LEFT UPRIGHT

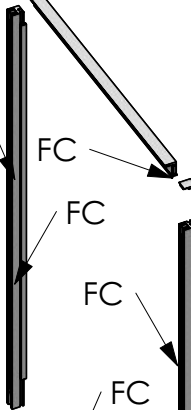

FC

FC

FC

FC

RIGHT UPRIGHT

RIGHT UPRIGHT

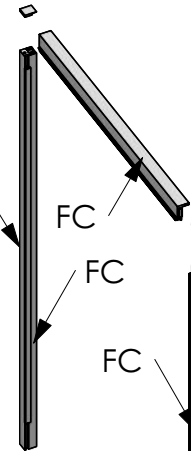

FC

FC

FC

FC

FC BOTTOM CHANNEL

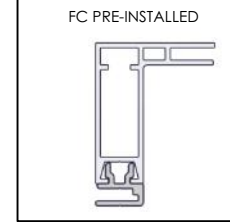

FC PRE-INSTALLED

LEFT UPRIGHT

CROSS BRACE TO UPRIGHTS

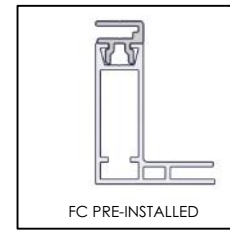

FC PRE-INSTALLED

FC TOP CHANNEL

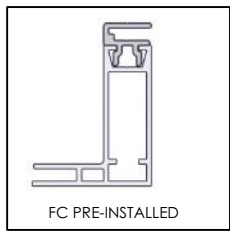



FC PRE-INSTALLED

FC TOP CHANNEL

CROSS BRACE TO UPRIGHTS

ASSEMBLY END FRAMES

QTY	IMAGE	DESCRIPTION
2		(38.65 w X 57.11 h total size ) 34.65 w X 53.11 h finish size, Unprinted 5oz. Black Soft Knit, sewn with silicone beading around perimeter & pull tab in bottom right corner
8		1/4"-20 x 1"L bolt

### SETUP INSTRUCTIONS

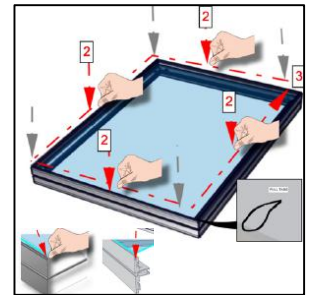

THEN PRESS ALONG THE PERIMETER EDGE

#### STEP 12

FIRST INSTALL INSIDE GRAPHICS

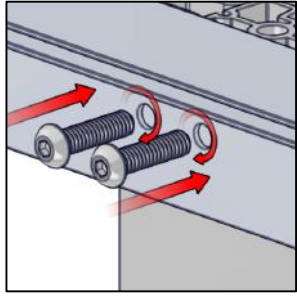
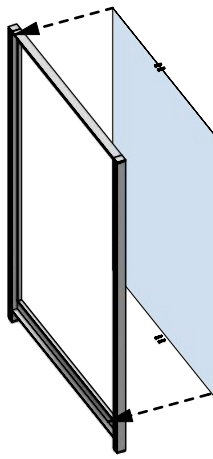
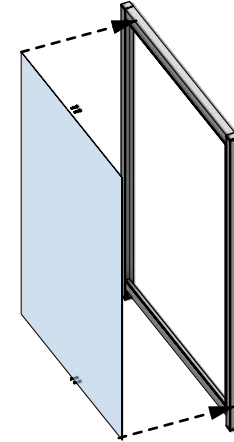

X2 MFY-BOLT-.25-20-1

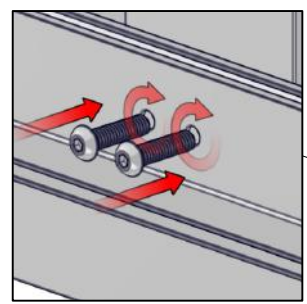

X2 MFY-BOLT-.25-20-1

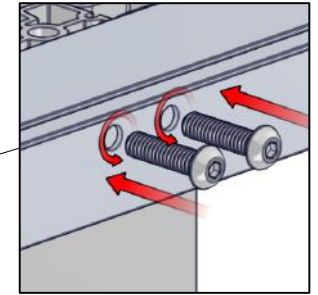

MFY-BOLT-.25-20-1 X2

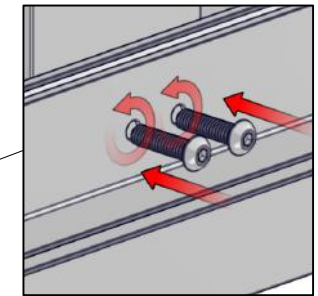

MFY-BOLT-.25-20-1 X2

#### STEP 13

BOLT LEFT & RIGHT FRAMES ONTO CENTER SECTION

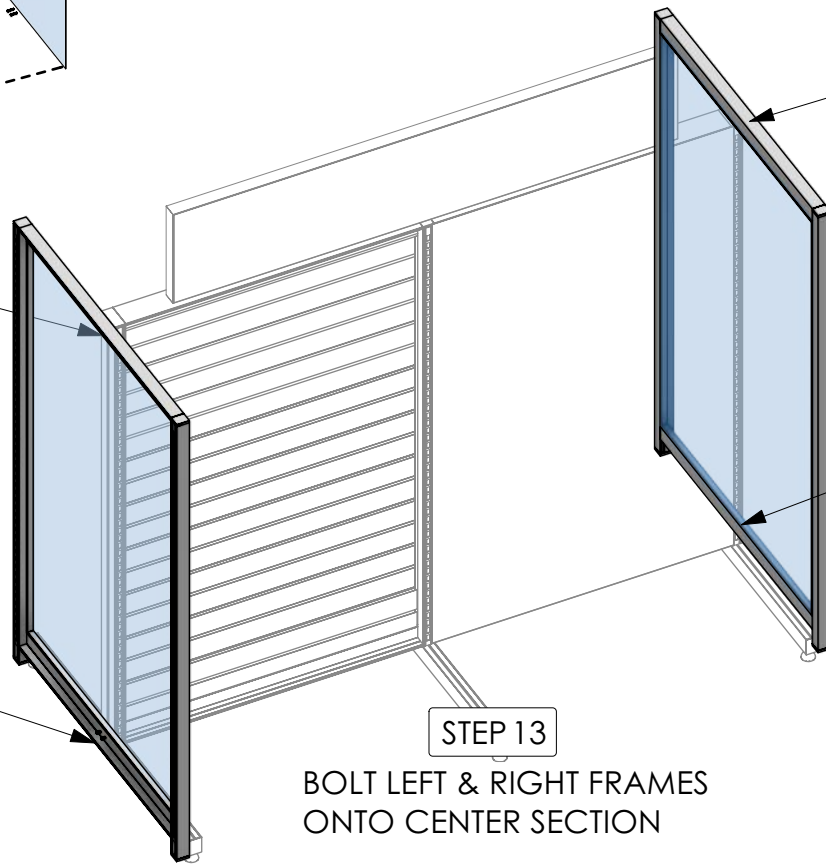

QTY	IMAGE	DESCRIPTION
2		(39.26 w X 60.65 h total size ) 35.26 w X 56.65 h finish size, Dye-sub print on Eclipse Blockout Stretch, single sided, sewn with FCE-2 silicone beading around perimeter & pull tab in bottom right corner

## SETUP INSTRUCTIONS

STEP 14

### INSTALL OUTSIDE END GRAPHICS

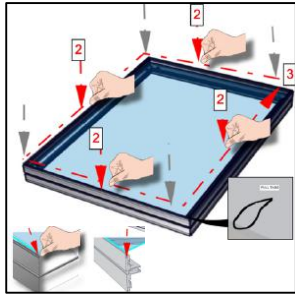

THEN PRESS ALONG THE PERIMETER EDGE

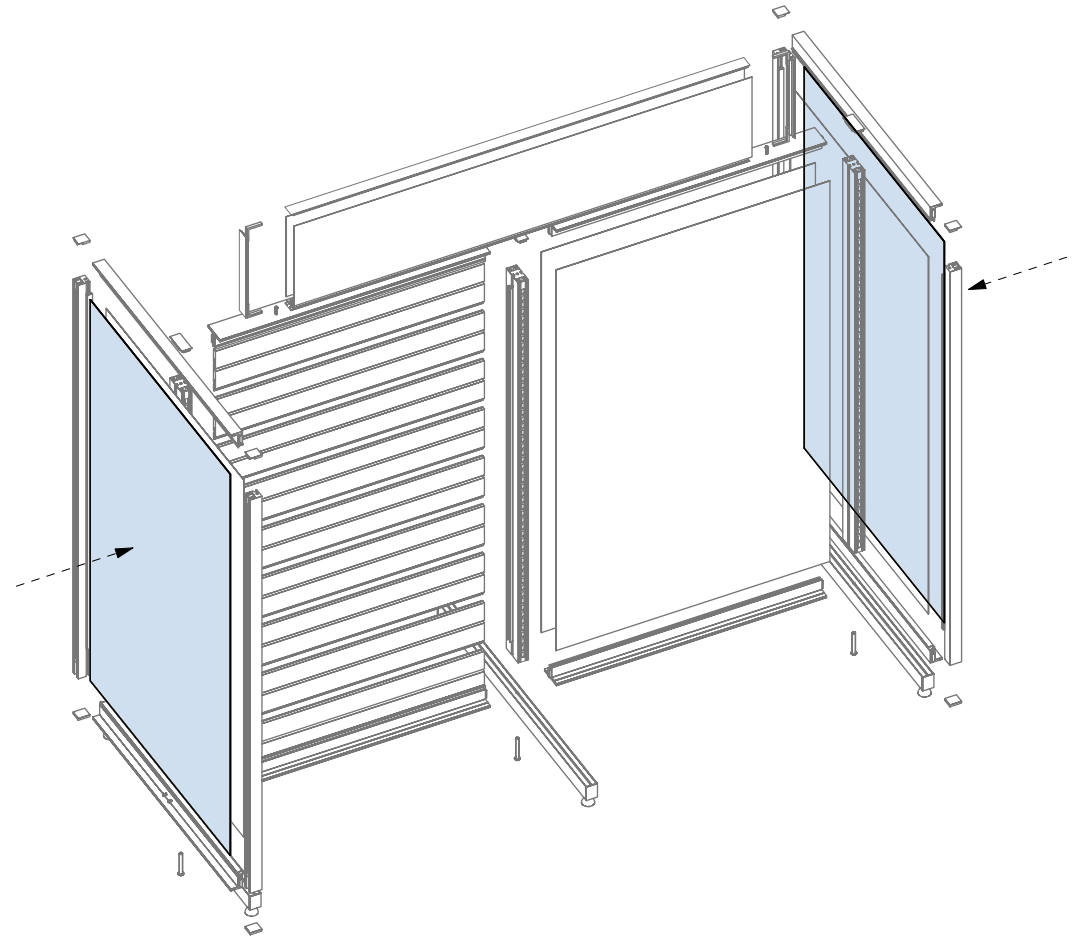
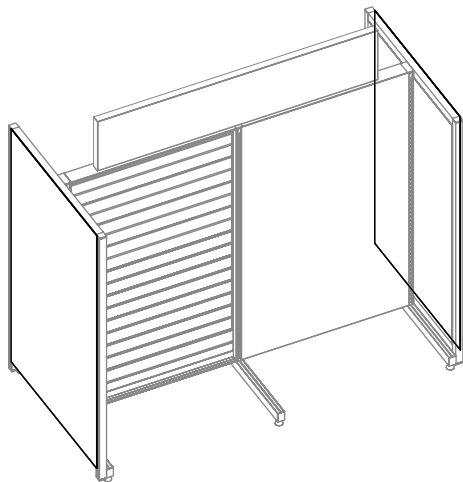

QTY	IMAGE	DESCRIPTION
4		36in WIDE X 17.25in DEEP - DROP-IN BASE PAN

SETUP INSTRUCTIONS

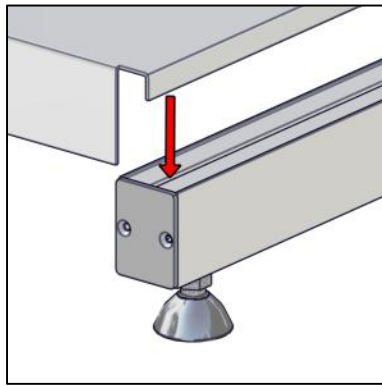



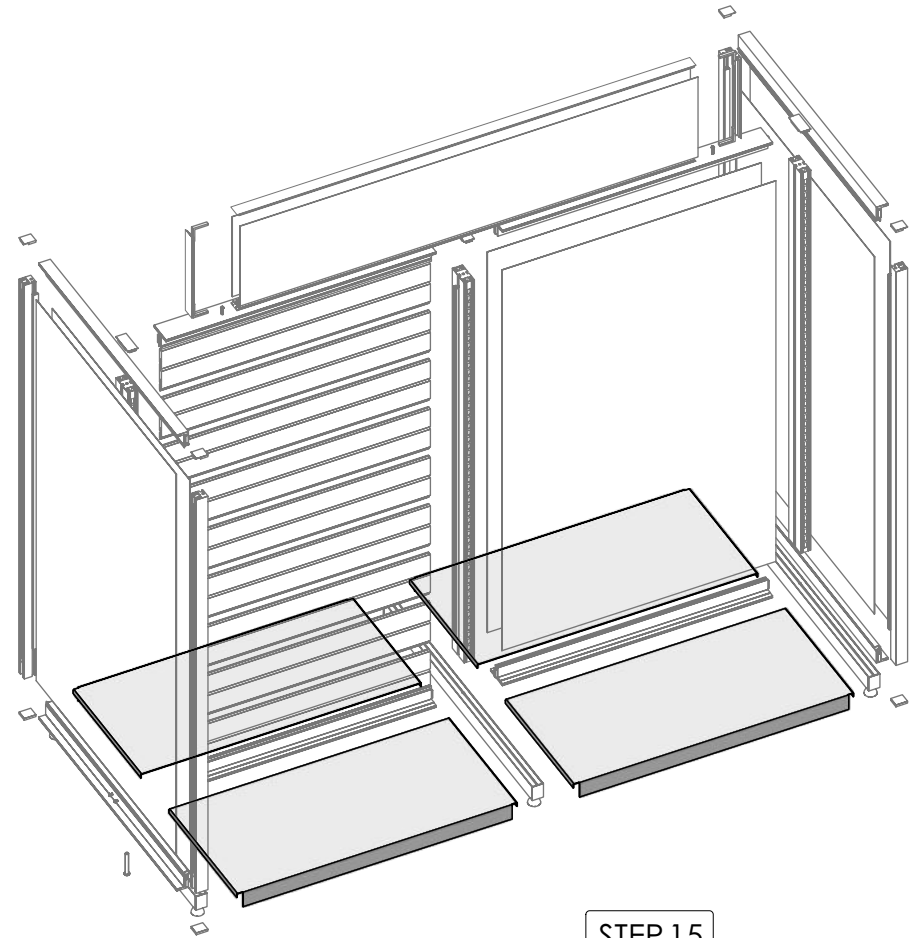
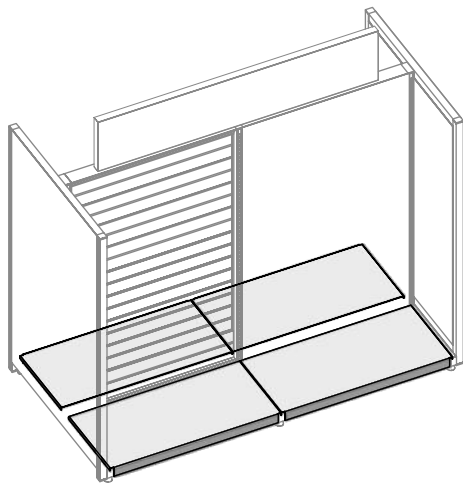



MFY-36-17-BASE-PAN











STEP 15

PLACE BASE PAN  
IN GROOVE(FOOT)

# Kit Hardware BOM

ITEM	COMPONENTS	QTY	DESCRIPTION
	004-883	2	883MM (34.76in) OF SWC EXTRUSION
	004-1335	2	1335MM (52.56in) OF SWC EXTRUSION
	005-879	8	879MM (34.61in) LENGTH OF SLOTWALL EXTRUSION
	005-879	1	879MM (34.61in) LENGTH OF SLOTWALL EXTRUSION -WITH 30MM BOTTOM CUT
	302-883-23-23	4	883MM CUT DOWN FROM 900MM LENGTH OF FC EXTRUSION-WITH ROUTES
	302-1338	4	1338MM CUT DOWN FROM 1500MM LENGTH OF FC EXTRUSION
	306-305-15-15	2	305MM (12.01in) LENGTH OF WMFCD EXTRUSION 45 DEGREE MITER CUT BOTH ENDS
	306-1500-15-15	2	1500MM (59.06in) LENGTH OF WMFCD EXTRUSION 45 DEGREE MITER CUT BOTH ENDS
	810-883-01-01	4	883MM (34.76in) OF SINGLE SIDED SEG EXTRUSION -WITH CAM LOCKS BOTH ENDS
	821-1486	2	1486MM (58.50in) RIGHT UPRIGHT
	821-1486	2	1486MM (58.50in) LEFT UPRIGHT
	821-EC	4	7MM SEG PLASTIC END CAP FOR 821 EXTRUSION
	824-947	1	947MM (37.28in) LEFT SUPPORT LEG
	824-947	1	947MM (37.28in) RIGHT SUPPORT LEG
	824-947	1	947MM (37.28in) LENGTH OF 824 CORNER POST EXTRUSION -WITH HOLE FOR 3/8 BOLT
	825-STOP-20A	4	2.0" END CAP STANDARD STOP, ALUMINUM
	832-1435	1	1435MM (56.50in) LEFT UPRIGHT
	832-1435	1	1435MM (56.50in) OF 832 DOUBLE SIDED UPRIGHT OPEN EXTRUSION
	832-1435	1	1435MM (56.50in) OF 832 RIGHT UPRIGHT
	832-EC	3	7MM SEG PLASTIC END CAP FOR 832 EXTRUSION
	835-883-01-01	4	883MM (34.76in) OF SINGLE SIDED SEG EXTRUSION -WITH CAM LOCKS BOTH ENDS
	MFY-36-17-BASE-PAN	4	36in WIDE X 17.25in DEEP - DROP-IN BASE PAN
	MFY-BOLT-.25-20-1	12	1/4"-20 x 1"L bolt
	MFY-BOLT-375-16-2.5	3	3/8-16 x 2.5-3"L bolt
	MFY-SLF-STD-56.5-PW	1	EXTRUSION
	VF-CC	4	SINGLE VECTOR CORNER CLEAT

# Kit Graphics BOM

	MFY-GN-01-A-G	1	(39.26 w X 60.65 h total size ) 35.26 w X 56.65 h finish size, Dye-sub print on Eclipse Blockout Stretch, single sided, sewn with FCE-2 silicone beading around perimeter & pull tab in bottom right corner
	MFY-GN-01-B-G	1	(38.65 w X 57.11 h total size ) 34.65 w X 53.11 h finish size, Unprinted 5oz. Black Soft Knit, sewn with silicone beading around perimeter & pull tab in bottom right corner
	MFY-GN-01-C-G	1	(39.26 w X 60.59 h total size ) 35.26 w X 56.59 h finish size, Dye-sub print on Eclipse Blockout Stretch, single sided, sewn with FCE-2 silicone beading around perimeter & pull tab in bottom right corner (WITH 1/4" NOTCH LEFT & RIGHT BOTTOM HORIZONTAL SIDE CORNERS)
	MFY-GN-01-D-G	1	(38.65 w X 57.11 h total size ) 34.65 w X 53.11 h finish size, Unprinted 5oz. Black Soft Knit, sewn with silicone beading around perimeter & pull tab in bottom right corner
	MFY-GN-01-E-G	1	(39.26 w X 60.65 h total size ) 35.26 w X 56.65 h finish size, Dye-sub print on Eclipse Blockout Stretch, single sided, sewn with FCE-2 silicone beading around perimeter & pull tab in bottom right corner
	MFY-GN-01-F-G	1	(39.26 w X 60.59 h total size ) 35.26 w X 56.59 h finish size, Dye-sub print on Eclipse Blockout Stretch, single sided, sewn with FCE-2 silicone beading around perimeter & pull tab in bottom right corner (WITH 1/4" NOTCH LEFT & RIGHT BOTTOM HORIZONTAL SIDE CORNERS)
	MFY-GN-01-G-G	1	(62.94 w X 15.88 h total size ) 58.94 w X 11.88 h finish size, Dye-sub print on Eclipse Blockout Stretch, single sided, sewn with FCE-2 silicone beading around perimeter & pull tab in bottom right corner
	MFY-GN-01-H-G	1	(62.94 w X 15.88 h total size ) 58.94 w X 11.88 h finish size, Dye-sub print on Eclipse Blockout Stretch, single sided, sewn with FCE-2 silicone beading around perimeter & pull tab in bottom right corner